

**Model HDX Static Hydraulic  
Universal Testing System**

**Operating Instructions**  
**M47-17031-EN      Revision B**

## Electromagnetic Compatibility

Where applicable, this equipment is designed to comply with International Electromagnetic Compatibility (EMC) standards.

To ensure reproduction of this EMC performance, connect this equipment to a low impedance ground connection. Typical suitable connections are a ground spike or the steel frame of a building.

---

## Proprietary Rights Notice

This document and the information that it contains are the property of Illinois Tool Works Inc. (ITW). Rights to duplicate or otherwise copy this document and rights to disclose the document and the information that it contains to others and the right to use the information contained therein may be acquired only by written permission signed by a duly authorized officer of ITW.

---

## Trademarks

Instron® is a registered trademark of Illinois Tool Works Inc. (ITW). Other names, logos, icons and marks identifying Instron products and services referenced herein are trademarks of ITW and may not be used without the prior written permission of ITW.

Other product and company names listed are trademarks or trade names of their respective companies.

---

## Original Instructions

Copyright © 2019 Illinois Tool Works Inc. All rights reserved. All of the specifications shown in this document are subject to change without notice.

---

### Corporate Headquarters

Instron  
825 University Avenue  
Norwood, MA 02062-2643  
United States of America

### European Headquarters

Instron  
Coronation Road  
High Wycombe, Bucks HP12 3SY  
United Kingdom

### Industrial Products Group

Instron  
900 Liberty Street  
Grove City, PA 16127  
United States of America

# General Safety Precautions



Materials testing systems are potentially hazardous.

Materials testing involves inherent hazards from high forces, rapid motions, and stored energy. You must be aware of all moving and operating components in the testing system that are potentially hazardous, particularly force actuators or a moving crosshead.

Carefully read all relevant manuals and observe all Warnings and Cautions. The term Warning is used where a hazard may lead to injury or death. The term Caution is used where a hazard may lead to damage to equipment or to loss of data.

Instron products, to the best of its knowledge, comply with various national and international safety standards, in as much as they apply to materials and structural testing. We certify that our products comply with all relevant EU directives (CE mark).

Because of the wide range of applications with which our instruments are used, and over which we have no control, additional protection devices and operating procedures may be necessary due to specific accident prevention regulations, safety regulations, further EEA directives or locally valid regulations. The extent of our delivery regarding protective devices is defined in your initial sales quotation. We are thus free of liability in this respect.

At your request, we will gladly provide advice and quotations for additional safety devices such as protective shielding, warning signs or methods of restricting access to the equipment.

The following pages detail various general warnings that you must heed at all times while using materials testing equipment. You will find more specific Warnings and Cautions in the text whenever a potential hazard exists.

Your best safety precautions are to gain a thorough understanding of the equipment by reading your instruction manuals and to always use good judgment.

It is our strong recommendation that you should carry out your own product safety risk assessment.

## Warnings



**Hazard - Press the Emergency Stop button whenever you consider that an unsafe condition exists.**

The Emergency Stop button removes hydraulic power or electrical drive from the testing system and brings the hazardous elements of the system to a stop as quickly as possible. It does not isolate the system from electrical power, other means are provided to disconnect the electrical supply. Whenever you consider that safety may be compromised, stop the test using the Emergency Stop button. Investigate and resolve the situation that caused the use of the Emergency Stop button before you reset it.



**Flying Debris Hazard - Make sure that test specimens are installed correctly in grips or fixtures in order to eliminate stresses that can cause breakage of grip jaws or fixture components.**



Incorrect installation of test specimens creates stresses in grip jaws or fixture components that can result in breakage of these components. The high energies involved can cause the broken parts to be projected forcefully some distance from the test area. Install specimens in the center of the grip jaws in line with the load path. Insert specimens into the jaws by at least the amount recommended in your grip documentation. This amount can vary between 66% to 100% insertion depth; refer to supplied instructions for your specific grips. Use any centering and alignment devices provided.



**Hazard - Protect electrical cables from damage and inadvertent disconnection.**

The loss of controlling and feedback signals that can result from a disconnected or damaged cable causes an open loop condition that may drive the actuator or crosshead rapidly to its extremes of motion. Protect all electrical cables, particularly transducer cables, from damage. Never route cables across the floor without protection, nor suspend cables overhead under excessive strain. Use padding to avoid chafing where cables are routed around corners or through wall openings.



**High/Low Temperature Hazard - Wear protective clothing when handling equipment at extremes of temperature.**



Materials testing is often carried out at non-ambient temperatures using ovens, furnaces or cryogenic chambers. Extreme temperature means an operating temperature exceeding 60 °C (140 °F) or below 0 °C (32 °F). You must use protective clothing, such as gloves, when handling equipment at these temperatures. Display a warning notice concerning low or high temperature operation whenever temperature control equipment is in use. You should note that the hazard from extreme temperature can extend beyond the immediate area of the test.

## Warnings

---



**Crush Hazard - Take care when installing or removing a specimen, assembly, structure, or load string component.**

Installation or removal of a specimen, assembly, structure, or load string component involves working inside the hazard area between the grips or fixtures. When working in this area, ensure that other personnel cannot operate any of the system controls. Keep clear of the jaws of a grip or fixture at all times. Keep clear of the hazard area between the grips or fixtures during actuator or crosshead movement. Ensure that all actuator or crosshead movements necessary for installation or removal are slow and, where possible, at a low force setting.



**Hazard - Do not place a testing system off-line from computer control without first ensuring that no actuator or crosshead movement will occur upon transfer to manual control.**

The actuator or crosshead will immediately respond to manual control settings when the system is placed off-line from computer control. Before transferring to manual control, make sure that the control settings are such that unexpected actuator or crosshead movement cannot occur.



**Robotic Motion Hazard - Keep clear of the operating envelope of a robotic device unless the device is de-activated.**

The robot in an automated testing system presents a hazard because its movements are hard to predict. The robot can go instantly from a waiting state to high speed operation in several axes of motion. During system operation, keep away from the operating envelope of the robot. De-activate the robot before entering the envelope for any purpose, such as reloading the specimen magazine.



**Hazard - Set the appropriate limits before performing loop tuning or running waveforms or tests.**

Operational limits are included within your testing system to suspend motion or shut off the system when upper and/or lower bounds of actuator or crosshead travel, or force or strain, are reached during testing. Correct setting of operational limits by the operator, prior to testing, will reduce the risk of damage to test article and system and associated hazard to the operator.



**Electrical Hazard - Disconnect the electrical power supply before removing the covers to electrical equipment.**

Disconnect equipment from the electrical power supply before removing any electrical safety covers or replacing fuses. Do not reconnect the power source while the covers are removed. Refit covers as soon as possible.

## Warnings

---

---



**Rotating Machinery Hazard - Disconnect power supplies before removing the covers to rotating machinery.**

Disconnect equipment from all power supplies before removing any cover which gives access to rotating machinery. Do not reconnect any power supply while the covers are removed unless you are specifically instructed to do so in the manual. If the equipment needs to be operated to perform maintenance tasks with the covers removed, ensure that all loose clothing, long hair, etc. is tied back. Refit covers as soon as possible.



**Hazard - Shut down the hydraulic power supply and discharge hydraulic pressure before disconnection of any hydraulic fluid coupling.**

Do not disconnect any hydraulic coupling without first shutting down the hydraulic power supply and discharging stored pressure to zero. Tie down or otherwise secure all pressurized hoses to prevent movement during system operation and to prevent the hose from whipping about in the event of a rupture.



**Hazard - Shut off the supply of compressed gas and discharge residual gas pressure before you disconnect any compressed gas coupling.**

Do not release gas connections without first disconnecting the gas supply and discharging any residual pressure to zero.



**Explosion Hazard - Wear eye protection and use protective shields or screens whenever any possibility exists of a hazard from the failure of a specimen, assembly or structure under test.**



Wear eye protection and use protective shields or screens whenever a risk of injury to operators and observers exists from the failure of a test specimen, assembly or structure, particularly where explosive disintegration may occur. Due to the wide range of specimen materials, assemblies or structures that may be tested, any hazard resulting from the failure of a test specimen, assembly or structure is entirely the responsibility of the owner and the user of the equipment.



**Hazard - Ensure components of the load string are correctly pre-loaded to minimize the risk of fatigue failure.**

Dynamic systems, especially where load reversals through zero are occurring, are at risk of fatigue cracks developing if components of the load string are not correctly pre-loaded to one another. Apply the specified torque to all load string fasteners and the correct setting to wedge washers or spiral washers. Visually inspect highly stressed components such as grips and threaded adapters prior to every fatigue test for signs of wear or fatigue damage.

## Table of Contents

<b>Chapter 1</b>	<b>Introduction</b>	<b>11</b>
	About these instructions	11
	System overview	12
	Purpose	12
	System components	12
	Frame configuration options	14
	Testing accessories	14
	System identification	14
	Frame components	15
	System control components	17
	System safety and information labeling	18
	Product support	19
	Product documentation	19
	System verification	19
<b>Chapter 2</b>	<b>Specifications</b>	<b>21</b>
	Use limits	21
	Frame	22
	Hydraulic power supply physical dimensions	26
	59 Series control unit	26
	Environmental conditions	26
	Heat load	27
	Noise level	27
<b>Chapter 3</b>	<b>Operation</b>	<b>29</b>
	Operation of controls	29
	Operation of HPS	33
	Mount fixtures	33
	Mount tension fixtures	33
	Mount compression fixtures	34
	Start the system	35
	Change height of tension test opening	36
	Adjust the position of the adjustable crosshead	36
	Adjust the position of the tension crosshead	36
	Equipment required	36
	Recommended procedure	36
	Change height of compression test opening	38
	Adjust the position of the adjustable crosshead	38

Operate grip assemblies . . . . .	39
Grip jaw selection . . . . .	40
Specimen guidelines . . . . .	40
General use guidelines . . . . .	41
Filler plate guidelines (G1-style crossheads only) . . . . .	42
Install grip jaws - G1-style crossheads . . . . .	43
Equipment and supplies required . . . . .	43
Recommended procedure . . . . .	43
Remove grip jaws - G1-style crossheads . . . . .	47
Equipment required . . . . .	47
Recommended procedure . . . . .	47
Install grip jaws - G7-style crossheads . . . . .	47
Equipment and supplies required . . . . .	48
Recommended procedure . . . . .	48
Remove grip jaws - G7-style crossheads . . . . .	51
Equipment and supplies required . . . . .	51
Recommended procedure . . . . .	51
Insert specimen . . . . .	52
Run a test . . . . .	53
Shut down the system . . . . .	55
Loss of power . . . . .	56
<b>Chapter 4 Maintenance . . . . .</b>	<b>57</b>
General maintenance recommendations . . . . .	57
Preventative maintenance schedule . . . . .	57
Make daily checks of system . . . . .	59
Remove and install console covers . . . . .	60
Electronics . . . . .	61
Clean the fans . . . . .	61
Fuses . . . . .	61
Inspect the cables . . . . .	61
Frame . . . . .	61
Check non-painted surfaces . . . . .	61
Adjustable crosshead . . . . .	62
Inspect the adjustable crosshead . . . . .	62
Lubricate the adjustable crosshead . . . . .	62
Inspect the hydraulic cylinder . . . . .	65
Grip assemblies . . . . .	67
Clean external surfaces and check operation of grip assemblies . . . . .	67
Lubricate the grip assemblies . . . . .	67
Lubrication Warning . . . . .	69



---

Clean and inspect grip components . . . . .	69
Equipment and supplies required . . . . .	69
Recommended procedure . . . . .	70
Inspect and replace the pinion - G1-style crossheads. . . . .	75
Hydraulic power supply (HPS) . . . . .	76
Check the oil cleanliness . . . . .	76
Add oil to reservoir . . . . .	76
Equipment and supplies required . . . . .	77
Recommended procedure . . . . .	77
Change the oil . . . . .	79
Equipment and supplies required . . . . .	79
Recommended procedure . . . . .	79
Change the air breather filter. . . . .	81
Equipment and supplies required . . . . .	81
Recommended procedure . . . . .	81
Inspect the hydraulic hoses . . . . .	81
Replace the hydraulic hoses . . . . .	81
Replace low pressure hydraulic hoses . . . . .	82
Replace high pressure hydraulic hoses . . . . .	82
Oil type and quantity . . . . .	82
Clean the air filter . . . . .	82
Ancillary parts . . . . .	83
Consumable parts . . . . .	85
Spare and replacement parts . . . . .	85
<b>Appendix A Grip Jaws . . . . .</b>	<b>87</b>



# Chapter 1

## Introduction

---

• About these instructions . . . . .	11
• System overview . . . . .	12
• Frame components . . . . .	15
• System control components . . . . .	17
• System safety and information labeling . . . . .	18
• Product support . . . . .	19
• Product documentation . . . . .	19
• System verification . . . . .	19

---

### About these instructions

These instructions describe the function, operation and maintenance for various models of the HDX testing systems. If unsure of your specific model, refer to “[System identification](#)” on page 14.

These instructions assume the following:

- You are an operator familiar with the operation of materials testing systems in general.
- Your system has been installed in its final location according to the requirements outlined in the system’s Pre-Installation Manual.
- Your system consists of a frame, a hydraulic power supply, a control unit, a computer system with an Instron materials testing software package, and any testing accessories necessary to secure the specimen in the test space.
- Software test methods that are appropriate for your testing requirements are available.

These instructions do not include the development of test methods within the materials testing software. This is covered in more advanced training that can be provided by Instron Service and Training departments.

Throughout your documentation are NOTE, CAUTION and WARNING statements that alert you to important information. They appear as follows:



*Notes provide further clarification on particular issues.*

---

### Caution

Cautions alert the user to situations that may cause equipment damage.

---

### Warning



Warnings alert the user to situations that may cause serious personal injury or death.

---

Please read these instructions, and any other documents provided, thoroughly and carefully. Be sure to understand all Warnings and Cautions before attempting to operate any of the system in whole or in part.

## System overview

### Purpose

#### Warning

---



If the equipment is used in a manner not specified by Instron, the protection provided by the equipment may be impaired. Injury to personnel or damage to the system may result. Be sure to read and understand the material presented in these instructions and in any other accompanying instructions.

---

The Instron Model HDX Static Hydraulic Universal Testing Systems are available in a variety of capacities. They have been developed for high-capacity testing to provide the forces necessary for static tension, compression, bend and shear testing. They are suited for tests on specimen samples such as bar, rebar, plate, tube, pipe, sheet, wire, and concrete. These frames feature two test spaces so that users can quickly change between tension and compression testing without having to remove heavy fixtures. This flexible design helps to ensure safety, reduce operator fatigue and improve productivity.

## System components

Model HDX systems consist of:

- Frame
- Hydraulic Power Supply (HPS)
- 59 Series control unit and other system controls and electronics
- Instron approved computer system with Instron materials testing software

[Figure 1](#) identifies the system components and various frame configurations (see “[Frame configuration options](#)” on page [14](#)).

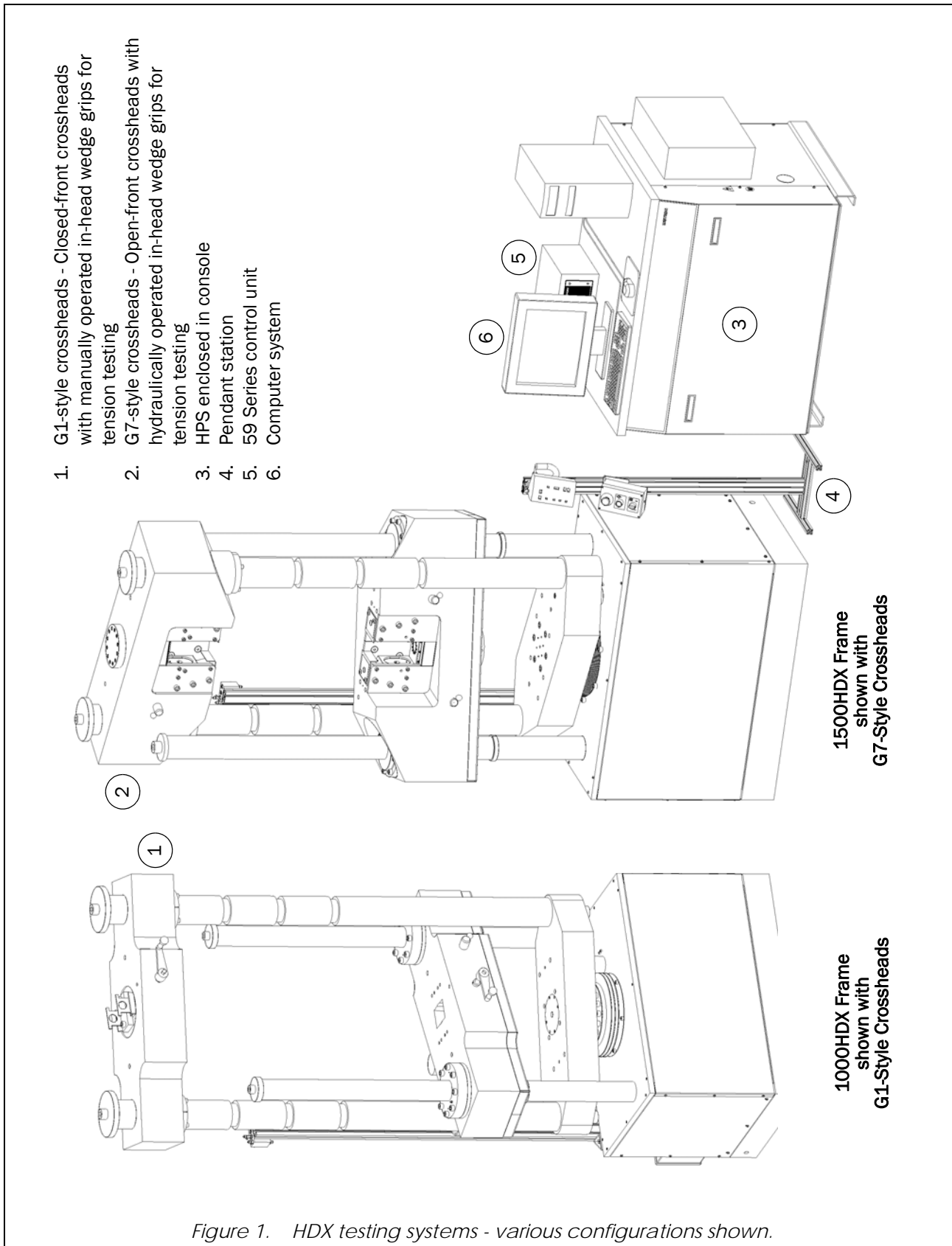

Figure 1. HDX testing systems - various configurations shown.

## Frame configuration options

Frames can be configured with a variety of options. These options include:

- Crosshead variations:
  - G1-style crossheads - Closed-front crossheads with manually operated grip assemblies for tension testing
  - G7-style crossheads - Open-front crossheads with hydraulically operated grip assemblies for tension testing
- Test opening variations:
  - B - Basic test openings
  - C - Increase tension and compression test spaces by: 508 mm (20 in) for 1000HDX frames, 610 mm (24 in) for 1500HDX frames

The configuration options selected for your frame are identified in the complete model number of the frame. The complete model number is defined as:

{Capacity (in kN)}{Model family}-{Crosshead style option}{Test opening option}

Some examples would be:

1000HDX-G1B, 1000HDX-G7C, 1500HDX-G1B, 1500HDX-G7B

It is very important to be aware of and understand the configuration of your frame as you perform various operations and procedures so that they can be performed correctly - the complete model number (in whole or in part) is used throughout this manual to identify specifications and procedures appropriate for your frame configuration. Knowing the complete model number of your frame is critical. To determine the complete model number (and thus configuration) of your frame, refer to one of the following:

- The frame serial tag (see “[System identification](#)” on page 14)
- The Instron quote

## Testing accessories

Testing accessories are purchased separately from the frame. Testing accessories either provide a means to secure the specimen in the test space or provide additional functionality to the frame. Instructions on the installation, use and maintenance of Instron testing accessories are provided separately with each testing accessory. A variety of testing accessories are available. Contact your Instron Sales Representative for more information.

## System identification

Your system has been given a unique serial number for system identification. This serial number can be found on the serial tag located on the rear of the frame (i.e. the frame serial tag). A duplicate serial tag can also be found on the rear of the HPS console.

In addition, the following components have also been given a unique serial number:

- **59 Series control unit** - This serial number can be found on the rear of the control unit.
- **HPS** - This serial number can be found on the rear of the HPS (rear cover of console must be removed).

The frame serial tag includes other important system information, including information on your frame's configuration. Frame configuration information can also be found on your Instron quote. Refer to “[Frame configuration options](#)” on page 14 for explanation of frame configuration.

## Frame components

Refer to [Figure 2](#) and [Table 1](#) to identify components of the frame. For proper operation of the system, it is important to be able to identify and to understand the basic function of these components.

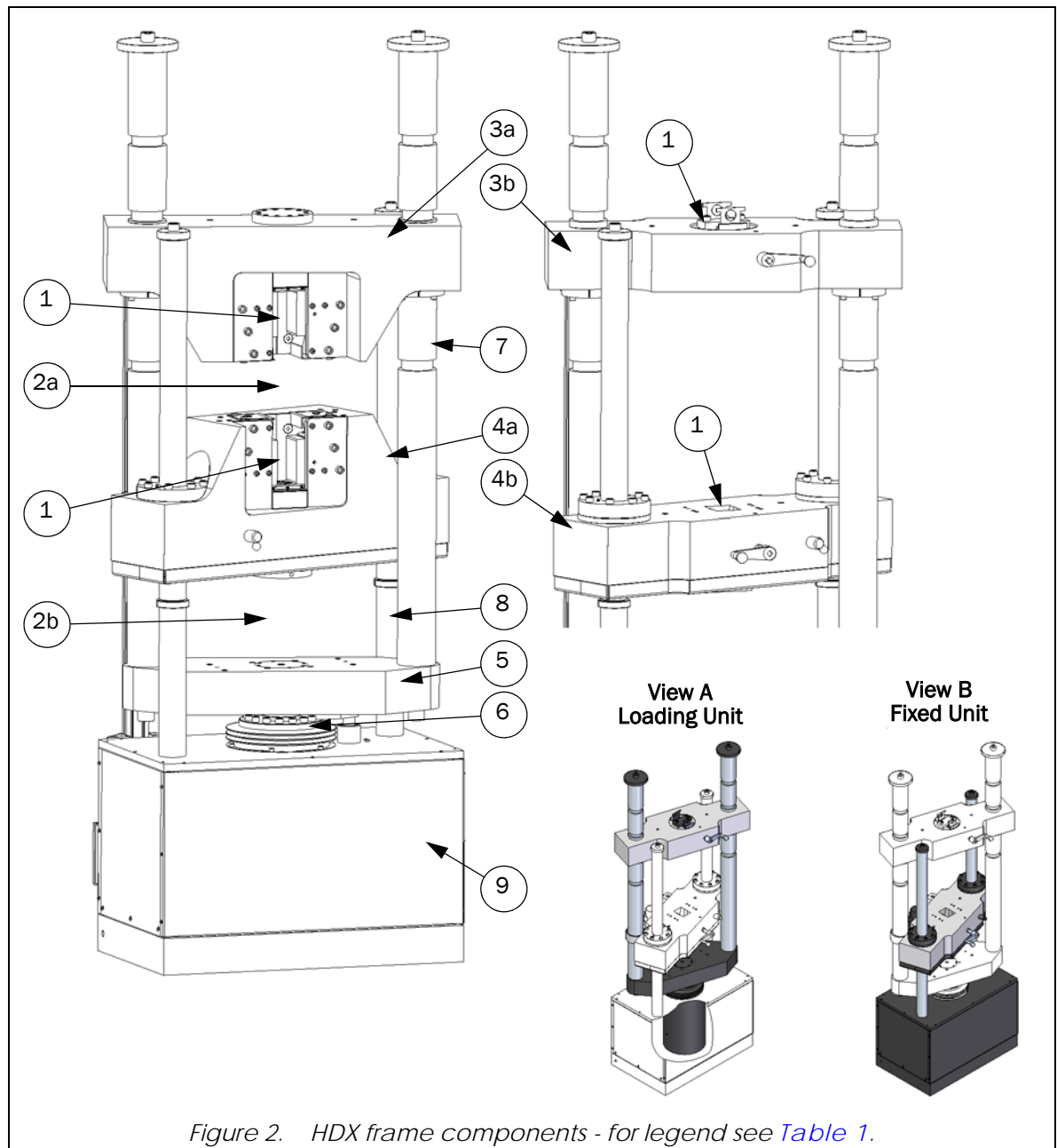

Table 1. Frame component descriptions, see Figure 2.







Component	Description
View A: Loading unit	Applies load to the specimen during the test. Consists of: a tension crosshead, two notched columns, a compression table, and the hydraulic cylinder.
View B: Fixed unit	Remains fixed during the test. Consists of: an adjustable crosshead, two screw columns, and the base.
1. Grip assemblies	Secure a specimen for tensile testing. Grip assemblies are operated either manually (G1-style crossheads) or hydraulically (G7-style crossheads). Refer to <a href="#">“Operate grip assemblies”</a> on page 39 for more information.
2. Test space a. Tension b. Compression	Area where tests are performed. The HDX is a dual test space frame. The tension test space is between the tension crosshead and adjustable crosshead. The compression test space is between the adjustable crosshead and compression table.  The vertical opening of each test space can be adjusted. Refer to <a href="#">“Change height of tension test opening”</a> on page 36 and <a href="#">“Change height of compression test opening”</a> on page 38 for more information.
3. Tension crosshead a. G7-style b. G1-style	Provides upper grip for tension specimen. Also provides mounting surface for external tension fixtures, refer to <a href="#">“Mount fixtures”</a> on page 33 for more information.  The position of the tension crosshead can be adjusted to change the vertical opening of the tension test space. Refer to <a href="#">“Adjust the position of the tension crosshead”</a> on page 36 for more information.
4. Adjustable crosshead a. G7-style b. G1-style	For <b>tension</b> testing, provides lower grip for tension specimen. Also provides mounting surface for external tension fixtures. Refer to <a href="#">“Mount fixtures”</a> on page 33 for more information.  For <b>compression</b> testing, the bottom of the crosshead provides mounting surface for upper compression fixtures - do not test directly against the bottom of the adjustable crosshead. Refer to <a href="#">“Mount fixtures”</a> on page 33 for more information.  The position of the adjustable crosshead can be adjusted to change the vertical opening of either test space. Refer to <a href="#">“Adjustable crosshead control switch”</a> on page 30 for more information.
5. Compression table	Provides mounting surface for lower compression fixtures - do not test directly against the compression table. Refer to <a href="#">“Mount fixtures”</a> on page 33 for more information.
6. Load cell	Measures the force applied to the specimen.
7. Notched columns	Connect the tension crosshead to the compression table. Notches allow position of tension crosshead to be adjusted. Refer to <a href="#">“Adjust the position of the tension crosshead”</a> on page 36 for more information.
8. Screw columns	Connect the adjustable crosshead to the base. Threaded portion of columns allows position of adjustable crosshead to be adjusted. Refer to <a href="#">“Adjustable crosshead control switch”</a> on page 30 for more information.
9. Base	Provides mounting for hydraulic cylinder.

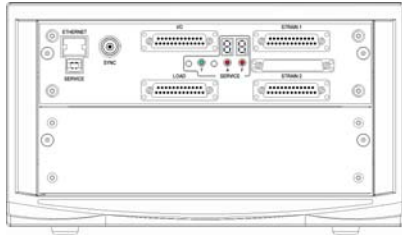

# System control components

Refer to [Table 2](#) to identify control components of the system. For proper operation of the system, it is important to be able to identify and to understand the basic function of these components.

Table 2. System control descriptions.

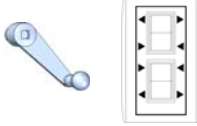
Component	Description
Emergency stop 	Press this button to immediately stop motion of the frame. This stops all frame motion and disables the frame. This button will take precedence over all other system controls. Refer to <a href="#">Table 10</a> on page <a href="#">29</a> for more information.
Main power disconnect switch 	Provides control of main power to the system. When the switch is off, all power to the frame and HPS are shut off. Power to the 59 Series control unit and computer system are unaffected as they have their own power supply.
Pump start 	Press this button to start the HPS. Refer to <a href="#">Table 10</a> on page <a href="#">29</a> for more information.
59 Series control unit 	The 59 Series control unit houses control components that: receive and process data from the various system transducers; communicate with the system's controlling software; and provide feedback to the system's servo valve to operate the frame as set up in the controlling software. Refer to <a href="#">Table 10</a> on page <a href="#">29</a> for more information.
59 Series control unit disconnect switch 	Provides control of power to the 59 Series control unit. This disconnect switch does not affect power to the frame.
User control panel 	The controls on this panel allow the operator to manually adjust the hydraulic cylinder, to start and stop tests, to reset and return to the zero extension point and other testing controls/functions. Refer to <a href="#">Table 10</a> on page <a href="#">29</a> for more information.
Adjustable crosshead control switch 	Allows the operator to jog the adjustable crosshead. This changes the height of both the tension test opening and the compression test opening.
Grip controls 	Allows the operator to open and close the grip jaws. Operated either manually (G1-style crossheads) or hydraulically (G7-style crossheads). Refer to <a href="#">"Operate grip assemblies"</a> on page <a href="#">39</a> for more information.

# System safety and information labeling

Table 3 explains the meanings of any safety and information labels that may be attached to any part of the testing system.

Table 3. Descriptions of safety and information labeling.















Label	Meaning and Purpose
	<p><b>Crush hazard</b> - Indicates that a pinching or crush hazard exists from two objects coming together and instructs the user to read and understand the operator’s manual before using the machine.</p>
	<p><b>Electrical hazard</b> - Indicates that a hazard exists from high voltage or electrical current.</p>
	<p><b>High pressure hazard</b> - Indicates that a hazard exists from high pressure. Do not adjust or reset any pressure settings until you have read and understood the operator’s manual. Personal injury or damage to equipment may result. Most pressure settings should only be adjusted by an Instron service engineer.</p>
	<p><b>Eye protection</b> - Indicates that a flying debris hazard exists either from specimen failure or improper use of system components. Wear eye protection or use protective shields or screens. Be sure to read and understand the operator’s manual before using the system.</p>
	<p><b>Read the manual</b> - Read and understand the operator’s manual before using the system.</p>
	<p><b>Guard removal hazard</b> - Indicates that a hazard exists - do not operate the system with covers removed. Be sure to read and understand the operator’s manual before using the system. Only authorized personnel should service the equipment.</p>
	<p><b>Guard removal hazard - chain drive inside</b> - Indicates that a hazard exists from a chain drive - do not operate the system with covers removed. Be sure to read and understand the operator’s manual before using the system. Only authorized personnel should service the equipment.</p>
	<p><b>Hand crush hazard</b> - Indicates that a pinching or crush hazard exists from two objects coming together - movement from the sides.</p>
	<p><b>Pinching hazard</b> - Indicates that an increased risk of pinching hazard exists if the grip closing speed is adjusted to be faster than 4 mm/sec (0.16 in/sec).</p>
	<p><b>Ground stud</b> - Indicates a ground stud. Connect to an appropriate ground/earth system.</p>
	<p><b>Protective earth</b> - Indicates the protective earth terminal for the main power supply.</p>
	<p><b>Three-phase power supply</b> - Indicates that the equipment requires a three-phase power supply.</p>
	<p><b>Grip engagement</b> - Indicates the proper amount of grip engagement to avoid damage to equipment.</p>
	<p><b>Grease location</b> - Indicates the location of grease fitting to apply appropriate lubricant.</p>

Table 3. Descriptions of safety and information labeling. (Continued)

Label	Meaning and Purpose
	<p>Jaw carrier's jaw pocket and back of jaw face must be free from grease, oil or debris. Lubrication of these surfaces may result in damage to carrier and dangerous projectiles.</p> <p>Ensure dust cover is installed during tension testing.</p>

## Product support

Instron provides documentation, including manuals and online help, that can answer many of the questions you may have. It is recommended that you review the documentation sent with the system you purchased for possible solutions to your questions.

If you cannot find answers in these sources, contact Instron's Services department directly. A list of Instron offices is available on our website at [www.instron.com](http://www.instron.com). You may email your questions to [service\\_support@instron.com](mailto:service_support@instron.com) (if your system is still in warranty, please include "IPG Warranty" in the subject line). In the US and Canada, you can call directly at 1-800-473-7838.

## Product documentation

Instron offers a comprehensive range of documentation to help you get the most out of your Instron products. Depending on what you have purchased, your documentation may include some or all of the following:

Pre-Installation Manual	Information about preparing your site for installation of the system, receiving the system, and lifting and handling of the system.
Operating Instructions	How to use your system components and controls, and other frequently performed operating tasks.
System Concepts	Additional information about your system.
Online Help	Software products come complete with context sensitive help, which provides detailed information on how to use all software features.
Accessory Equipment Reference	How to set up and use any accessories you have purchased, for example grips, fixtures, extensometers, transducers, hydraulic power units, non-standard actuators, and environmental chambers.

We welcome your feedback on any aspect of the product documentation. Please email [info\\_dev@instron.com](mailto:info_dev@instron.com) with your comments.

## System verification

### Caution

System verification is vital to ensure the accuracy of your calibration. Current standards recommend that you do not exceed 18 months between verifications.

Instron provides a fully traceable verification service including UKAS/NVLAP certification where appropriate. Contact your local Instron Representative for details.



# Chapter 2

## Specifications

- Use limits . . . . . 21
- Frame . . . . . 22
- Hydraulic power supply physical dimensions . . . . . 26
- 59 Series control unit . . . . . 26
- Environmental conditions . . . . . 26
- Heat load . . . . . 27
- Noise level . . . . . 27

### Use limits

Table 4 gives information on the use limits of the testing system, as determined in accordance with ISO 12100, section 5.3.2.

*Table 4. Use limits of the testing system.*

<b>Intended use and foreseeable misuse:</b>	<p>When fit with appropriate fixtures, the system is intended to conduct static tension, compression, bend, flexure and shear tests on a variety of specimen shapes and material types. The material types must be limited to those that break into no more than two pieces that will be retained in the fixtures or whose failure does not result in hazardous projectiles. The system can operate in servo control mode only through an Instron Materials Testing Software package. The system must never be left unattended while in operation.</p> <p>The system should not be used for any purpose other than static testing of the material types specified above. It must not be used to test specimens of material types that result in hazardous projectiles unless an interlocked guard with an appropriate performance level is added. You must conduct your own risk assessment and take appropriate measures to prevent operator injury and guard the equipment. Instron offers safety rated guards for this purpose. Please contact your local Instron representative for more information.</p> <p>The system must not be used as a press. The system should not be operated by anyone who does not fit the criteria specified in the “<a href="#">Operator characteristics:</a>” and “<a href="#">Operator training/experience:</a>” sections of this table.</p>
<b>Intervention procedures:</b>	The system is equipped with <b>Emergency Stop</b> and software reset (frame enable) controls (see <a href="#">Table 2</a> on page <a href="#">17</a> and separately supplied Software documentation).
<b>Use type:</b>	Industrial
<b>Operator characteristics:</b>	Typical adult in good health with no disabilities that prevent safe operation of the testing system.
<b>Operator training/experience:</b>	<p><b>Operators</b> should be familiar with the operation of materials testing systems in general and with the inherent hazards of such testing in particular. Operators should gain a thorough understanding of this equipment by reading these instructions and all other documents provided. Initial basic safety and operational training is provided by Instron Service personnel during installation of the system.</p> <p><b>Maintenance personnel or technicians</b> should have sufficient training and skills so that they can safely perform all procedures outlined in <a href="#">Chapter 4</a> beginning on page <a href="#">57</a>.</p> <p><b>Trainees and apprentices</b> should only operate or maintain the system under direct supervision of a qualified operator or maintenance personnel.</p> <p><b>The general public</b> should not have access to the system.</p>

Table 4. Use limits of the testing system. (Continued)

<b>Exposure of other persons to hazards:</b>	Exposure to hazards is greatly reduced by the knowledge of qualified operators. Anyone who does not fit the criteria specified in the “Operator characteristics:” and “Operator training/experience:” sections of this table should not have access to the system.
--	--

## Frame

The technical specifications for the various standard HDX frames can be found in Table 5. If unsure of the options included with your frame, check the model number listed on the frame’s serial number tag; it includes option designations.

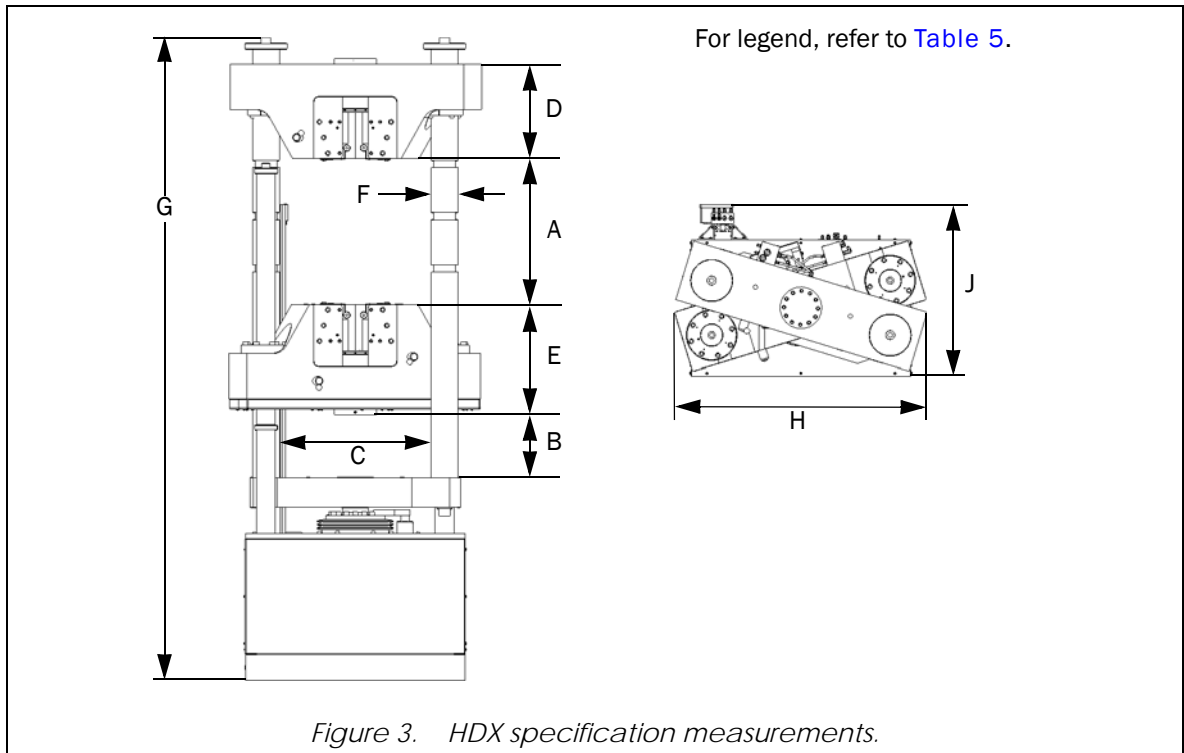

Table 5. HDX frame technical specifications.

Specification <sup>1</sup>	1000HDX	1500HDX
Maximum Capacity <sup>2</sup>	1,000 kN 100,000 kgf 225,000 lbf	1,500 kN 150,000 kgf 337,500 lbf
Design Capacity <sup>3</sup>	800 kN 80,000 kgf 180,000 lbf	1,200 kN 120,000 kgf 270,000 lbf
(A) Tension Test Opening (per crosshead style, frame height and tension crosshead position) <sup>4</sup>		

Table 5. HDX frame technical specifications. (Continued)

Specification <sup>1</sup>		1000HDX	1500HDX
G1B	First notch	0 - 762 mm (0 - 30 in)	76 - 686 mm (3 - 27 in)
	Second notch	0 - 1016 mm (0 - 40 in)	76 - 991 mm (3 - 39 in)
	Third notch	152 - 1270 mm (6 - 50 in)	76 - 1295 mm (3 - 51 in)
	Fourth notch	406 - 1524 mm (16 - 60 in)	N/A
G7B	First notch	N/A <sup>5</sup>	0 - 457 mm (0 - 18 in)
	Second notch	0 - 508 mm (0 - 20 in)	0 - 762 mm (0 - 30 in)
	Third notch	0 - 762 mm (0 - 30 in)	0 - 1067 mm (0 - 42 in)
	Fourth notch	0 - 1016 mm (0 - 40 in)	N/A
G7C	First notch	N/A <sup>5</sup>	0 - 457 mm (0 - 18 in)
	Second notch	0 - 508 mm (0 - 20 in)	0 - 762 mm (0 - 30 in)
	Third notch	0 - 762 mm (0 - 30 in)	0 - 1067 mm (0 - 42 in)
	Fourth notch	0 - 1016 mm (0 - 40 in)	0 - 1372 mm (0 - 54 in)
	Fifth notch	0 - 1270 mm (0 - 50 in)	0 - 1676 mm (0 - 66 in)
	Sixth notch	0 - 1524 mm (0 - 60 in)	N/A
<b>(B) Compression Test Opening<sup>6</sup></b>		Refer to the appropriate General Assembly drawing provided in the "Reference Manual-Equipment" <sup>7</sup>	
<b>Tension Specimen Size, Flat, Maximum<sup>8</sup> (thickness x width)</b>			
G1		50 x 82 mm (2 x 3.25 in)	76 x 89 mm (3 x 3.5 in)
G7		70 x 100 mm (2.75 x 4 in)	70 x 100 mm (2.75 x 4 in)
<b>Tension Specimen Size, Round, Minimum and Maximum<sup>8</sup> (diameter)</b>			
G1		6 - 82 mm (0.25 - 3.25 in)	10 - 82 mm (0.375 - 3.25 in)
G7		3 - 70 mm (0.12 - 2.75 in)	3 - 70 mm (0.12 - 2.75 in)
<b>(C) Horizontal Test Width</b>		741 mm (29.188 in)	762 mm (30 in)
<b>Horizontal Test Depth</b>		356 mm (14 in)	457 mm (18 in)
<b>Stroke</b>		254 mm (10 in)	305 mm (12 in)
<b>Adjustable Crosshead Travel</b>			
G1B		864 mm (34 in)	914 mm (36 in)
G7B		864 mm (34 in)	762 mm (30 in)
G7C		1372 mm (54 in)	1372 mm (54 in)

Table 5. HDX frame technical specifications. (Continued)

Specification <sup>1</sup>	1000HDX	1500HDX
<b>(D, E) Crosshead Thickness</b>		
G1 - Upper	197 mm (7.75 in)	248 mm (9.75 in)
G1 - Lower	273 mm (10.75 in)	330 mm (13 in)
G7 - Upper	457 mm (18 in)	457 mm (18 in)
G7 - Lower	533 mm (21 in)	533 mm (21 in)
<b>(F) Column Diameter</b>	127 mm (5 in)	140 mm (5.5 in)
<b>(G) Maximum Overall Height</b>	Refer to the appropriate General Assembly drawing provided in the "Reference Manual-Equipment" <sup>7</sup>	
<b>Overall Frame Area</b> (width (H) x depth (J))	1228 x 832 mm (48.375 x 32.75 in)	1279 x 962 mm (50.375 x 37.875 in)
<b>Weight<sup>9</sup></b>	Refer to the appropriate General Assembly drawing provided in the "Reference Manual-Equipment" <sup>7</sup>	
<b>Speed Information</b>		
<b>Testing Speed Range</b> (at full load)	0.1 to 101.6 mm/min (0.004 to 4 in/min)	0.1 to 114.3 mm/min (0.004 to 4.5 in/min)
<b>Jog (Adjusting) Speed</b> (Maximum)	101.6 mm/min (4 in/min)	114.3 mm/min (4.5 in/min)
<b>Adjustable Crosshead Speed<sup>10</sup></b> (Maximum)	305 mm/min (12 in/min)	305 mm/min (12 in/min)
<b>Position Information</b>		
<b>Accuracy<sup>11, 12</sup></b>		
C3	Equal to or less than +/-0.254 mm (0.010 in) or +/-1.0% of displayed reading, whichever is greater	
C4	Equal to or less than +/-0.13 mm (0.005 in) or +/-0.5% of displayed reading, whichever is greater	
<b>Resolution<sup>11, 13</sup></b>		
C3	6.35 µm (0.00025 in)	
C4	1.27 µm (0.00005 in)	
<b>Cyclic Test and Frequency Limits</b>	Capable of tension/tension or compression/compression cyclic testing only. Cyclic tests are limited to ramp type waveforms as defined within the materials testing software package being used with the system. Frequency limits are defined by the compliance of the specimen and the dynamic control limit of the system. The frame uses a single acting hydraulic cylinder to apply load and is not capable of forced unloading through hydraulics and relies solely on specimen compliance and/or gravity to return the piston. Therefore, cycling performance is completely dependent on specimen characteristics. In all cases, the frequency for cyclic testing is limited to 1 Hz or less.	
<b>Grip Wedge Pocket Alignment<sup>14</sup></b>		
G1	Within +/-1.27 mm (0.050 in) left to right and front to rear	
G7	Within +/-0.64 mm (0.025 in) left to right and front to rear	



Table 5. HDX frame technical specifications. (Continued)

Specification <sup>1</sup>	1000HDX	1500HDX
Compression Test Space Parallelism <sup>15</sup>	0.20 mm (0.008 in)	
<b>Power Requirements</b>		
Power option A	208/230 VAC, 3 Ph, 50/60 Hz, 15 A	208/230 VAC, 3 Ph, 50/60 Hz, 30 A
Power option B	380/400/415 VAC, 3 Ph, 50/60 Hz, 10 A	380/400/415 VAC, 3 Ph, 50/60 Hz, 20 A
Power option C	460 VAC, 3 Ph, 50/60 Hz, 10 A	460 VAC, 3 Ph, 50/60 Hz, 15 A
<b>Certifications</b>	Conform to all relevant European standards and carry a CE mark	

1. G1 = Dual test space with open-front crossheads and manual crank and pinion grip actuation  
G7 = Dual test space with open-front crossheads and hydraulic grip actuation  
B = Basic test openings  
C = Increase tension and compression test spaces by:
  - 508 mm (20 in) for 1000HDX frames
  - 610 mm (24 in) for 1500HDX frames
2. Long term static tests should be limited to 30 minutes or less when the test is performed at or near maximum capacity. Time varies inversely with test load. 50% maximum capacity tests should be limited to 60 minutes or less. An oil temperature switch limits test duration based on safe reservoir temperature. Assumes ambient temperature of 25 deg C (77 deg F).
3. The design capacity is the peak load at which the frame should be used for no more than 80% of the time. In other words, at least 80% of specimen testing should be conducted at peak loads that are at or below the design capacity. The frame should only be used at loads between the design capacity and the maximum capacity less than 20% of the time.
4. Minimum and maximum tension opening is provided for each crosshead style and each notch position of the tension crosshead. First notch position is with the tension crosshead in the lowest notch on the columns. Number of notch positions provided depends on frame height option purchased; not all frames have all notch positions listed. Minimum opening is with the hydraulic cylinder fully retracted and the adjustable crosshead in highest position. Maximum opening is with the hydraulic cylinder fully extended and the adjustable crosshead in lowest position. Values do not include crosshead thickness or any specimen fixtures.
5. First notch should not be used; crosshead interference can occur.
6. Minimum compression test opening measured with the hydraulic cylinder fully extended and adjustable crosshead in lowest position. Maximum compression test opening measured with the hydraulic cylinder fully retracted and adjustable crosshead in highest position. Values do not include specimen fixtures.
7. The General Assembly drawing is located in the separately supplied "Reference Manual-Equipment". General Assembly drawings are model specific; please be sure to refer to the appropriate drawing for your model and its configuration.
8. Several sets of grip jaws may be required to cover the range.
9. Weight does not include grips, fixtures, HPS, or control equipment.
10. Adjustable crosshead speed is approximate and provided for reference only. Adjustment speed may vary depending on crosshead type and fixtures attached to adjustable crosshead.
11. C3 = Hydraulic cylinder position/Speed measurement (standard resolution)  
C4 = Hydraulic cylinder position/Speed measurement (high resolution)
12. Under no load conditions. Accuracy is affected under load. The encoder cannot compensate for frame deflection (axial stiffness) or the load cell and load string deflections. Over short travels and higher loads, the error could be over 100%. Conversely, over longer travels and lower loads, the error may be insignificant. The axial frame stiffness and load cell stiffness values published may be used to assess this affect. The load string also needs to be considered. In general, the extension (position) readout should not be used as the primary strain measuring device where an extensometer on the specimen is clearly warranted. Frame compliance can be accounted for to some extent by Instron software.
13. At speeds below approximately 0.1 mm/min (0.004 in/min) the hydraulic cylinder moves in increments approximately equal to these values and can be seen as load steps depending on the specimen stiffness and load range.
14. Alignment of the grip wedge pockets is measured with approximately 200 mm (8 in) between crossheads in the tension test space.
15. Parallelism is measured under no load conditions between the table and the adapter on the underside of the adjustable crosshead.

## Hydraulic power supply physical dimensions

Table 6. Dimensions of standard HPS models.

HPS Catalog Number	HPS Model	Height	Required Floor Space (W x D) <sup>1</sup>	Approx. Weight
1000HDX-D22	V11f	1038 mm (40.9 in)	755 x 959 mm (29.75 x 37.75 in)	365 kgs (800 lbs)
1500HDX-D14	V12f	1038 mm (40.9 in)	1365 x 959 mm (53.75 x 37.75 in)	680 kgs (1,500 lbs)

1. Width does not include clearance to open the electrical box door. Clearance needed to open the door is 355 mm (14 in).

## 59 Series control unit

Table 7. 59 Series control unit technical specifications.

<b>Data Sampling</b>	40 kHz
<b>Data Capture</b>	Selectable up to 1000 Hz <sup>1</sup> Intelligent data capture Synchronous on all channels
<b>Digital Signal Processor</b>	32-bit floating point Self-test diagnostics Real-time closed-loop control Real-time data acquisition
<b>Data Transfer to Computer</b>	1000 Hz
<b>Transducer Inputs</b>	Standard Instron rationalized transducers Any 0-10 V analog DC input
<b>Transducer Resolution</b>	1 part in 500,000 of +/- full scale (19 bits)
<b>Load Measurement Accuracy</b>	+/- 0.5% of reading down to 1/500 of load cell capacity
<b>Linearity</b>	+/- 0.25% of reading over a range of 0.2% to 100% of capacity
<b>Repeatability</b>	+/- 0.25% of reading over a range of 0.2% to 100% of capacity
<b>Strain Measurement Accuracy</b>	+/- 0.5% of reading down to 1/50 of full range with ASTM E 83 class B-1 or B-2, or ISO 9513 class 0.5 extensometer
<b>Certifications</b>	Conform to all relevant European standards

1. Software data capture rate may vary.

## Environmental conditions

Table 8 lists the recommended environmental conditions in which the system should be operated and stored.

Table 8. Recommended environmental conditions.

<b>Operating Temperature:</b>	+10 to +38 deg C (+50 to +100 deg F)
-------------------------------	--------------------------------------

Table 8. Recommended environmental conditions.

<b>Storage Temperature:</b>	-40 to +66 deg C (-40 to +150 deg F)
<b>Humidity:</b>	10% to 90% (non-condensing)
<b>Atmosphere:</b>	Designed for use under normal laboratory conditions. Protective measures may be required if excessive dust, corrosive fumes, electromagnetic fields, or hazardous conditions are encountered.

## Heat load

The HPS generates a certain amount of heat during operation. Refer to [Table 9](#) for the approximate heat output of the HPS operating at both a 10% duty cycle and 50% duty cycle. The duty cycle is defined as the amount of time that the HPS operates under full load conditions. For example, operating at a 10% duty cycle would mean performing approximately one 6-minute test at full load per hour.

Table 9. Approximate heat output of various HPS models.

HPS Catalog Number	HPS Model	Approximate Heat Output at 10% Duty Cycle	Approximate Heat Output at 50% Duty Cycle
1000HDX-D22	V11f	0.77 kW (2639 BTU/hour)	1.34 kW (4665 BTU/hour)
1500HDX-D14	V12f	0.85 kW (2890 BTU/hour)	1.84 kW (6290 BTU/hour)

## Noise level

The A-weighted emission sound pressure level generated by the testing system under normal operating conditions does not exceed 70 dBA. The peak C-weighted instantaneous sound pressure value does not exceed 63 Pa.

Since many variables (such as room layout) affect noise levels, it can not be assumed that these readings will be equal to those in the field. The noise level readings were taken at a location in front of the system as shown in [Figure 4](#). This is the typical location for an operator to stand when operating the system.

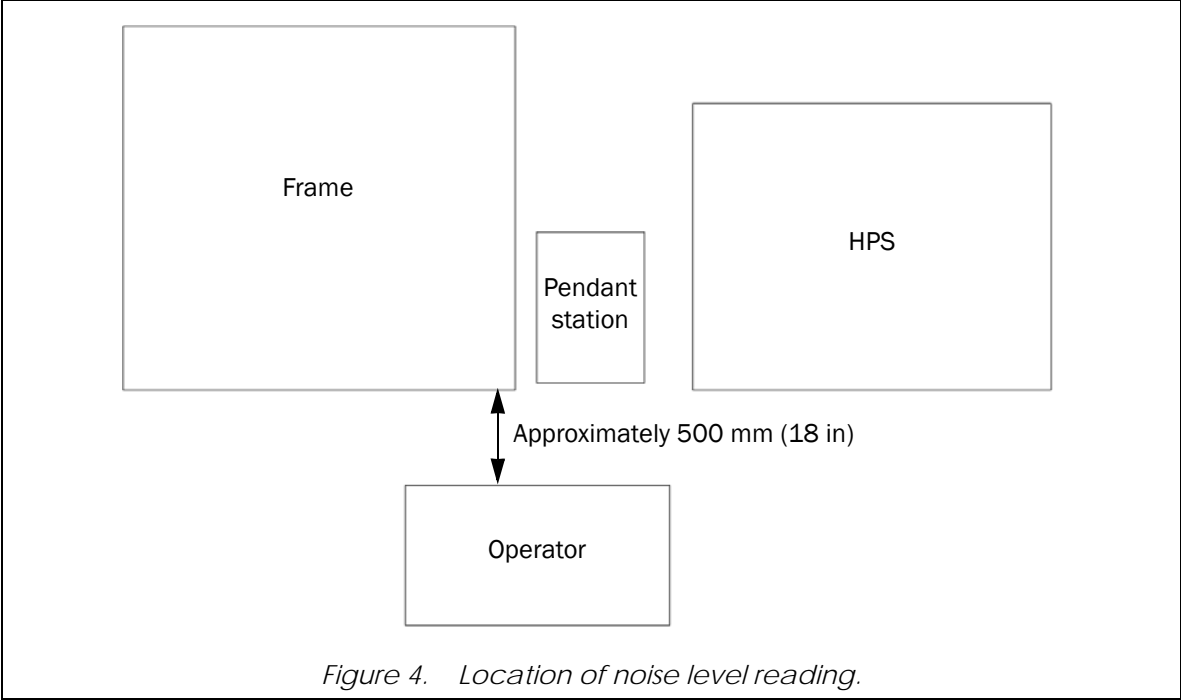

Figure 4. Location of noise level reading.

# Chapter 3

## Operation

- Operation of controls ..... 29
- Operation of HPS..... 33
- Mount fixtures..... 33
- Start the system ..... 35
- Change height of tension test opening ..... 36
- Change height of compression test opening..... 38
- Operate grip assemblies..... 39
- Run a test ..... 53
- Shut down the system ..... 55
- Loss of power ..... 56

### Warning



Always wear appropriate personal protective equipment when preparing, operating and maintaining this equipment. Personal protective equipment should include, but is not limited to, eye protection and head protection. Other types of personal protective equipment may also be needed. You must perform your own risk assessment and take appropriate measures to protect yourself from harm.

## Operation of controls

Table 10 provides details on the function and operation of various system controls. The controls supplied with the system depend on options purchased - not all controls listed in Table 10 are supplied with every system.

Table 10. Control functions.

Control	Location	Description
<b>Emergency stop</b> 	HPS control box	When it is necessary to stop motion of the frame immediately, press the <b>Emergency Stop</b> button. This shuts down the HPS and disables the frame. To resume operation: <ol style="list-style-type: none"> <li>1. Release the <b>Emergency Stop</b> button by turning it clockwise as depicted by the arrows on the knob face.</li> <li>2. Enable the frame in the controlling software.</li> <li>3. Press the <b>Pump Start</b> button. The green indicator light should illuminate and the HPS should start.</li> </ol>
<b>Pump start</b> 	HPS control box	Turns on the HPS. The frame must be enabled through the controlling software before the HPS can be started. The button will illuminate when the HPS is on.

Table 10. Control functions. (Continued)

Control	Location	Description
<b>Adjustable crosshead control switch</b> 	Adjustable crosshead	<p>Adjust the position of the adjustable crosshead either before or after a test. This changes the height of both the tension test opening and the compression test opening. Do not apply a load to the specimen using this switch. If this control will not function, be sure the <b>Emergency Stop</b> button is released. Move the adjustable crosshead as follows:</p> <ol style="list-style-type: none"> <li>1. <a href="#">Start the system; see page 35</a>. Start the HPS.</li> <li>2. Rotate the switch in the required direction - <b>Up</b> and <b>Down</b> arrows indicate resulting crosshead direction.</li> <li>3. Hold the switch until the crosshead is at the required height.</li> <li>4. Release the switch. The switch automatically returns to its neutral position and crosshead motion stops.</li> </ol>
<b>Display and associated buttons</b>	User control panel ( <a href="#">Figure 5</a> )	<p>The display and its associated buttons operate together with the controlling software. The numbered buttons, labeled <b>1, 2, 3</b> and <b>4</b>, operate as either “soft keys” or “live display keys” and the button to the left of the display is the toggle button that switches the numbered buttons between those two operations.</p> <p>As soft keys, you can assign up to four functions that you use frequently, such as Balance Load. Any soft key functions that you have assigned in the controlling software are shown in the display next to the appropriate button. Pressing a button performs the action displayed next to it.</p> <p>As live display keys, you can assign up to four live displays. The live displays are copies of any live displays that you have set up in the controlling software.</p> <p>If the display is showing live displays you must toggle back to show the soft key functions if you want to use a soft key button on the control panel.</p> <p>For information on setting up the display and numbered buttons; refer to the controlling software’s On-line Help.</p>
<b>Jog Controls</b>	User control panel ( <a href="#">Figure 5</a> )	<p>These buttons actuate the piston of the hydraulic cylinder in the direction indicated. When the <b>JOG DOWN</b> button is held longer than three seconds, the dump valve will open to allow oil to return directly to the reservoir, thus providing for a faster unload rate. The dump valve actually cycles to maintain the error signal within prescribed limits. This can cause a pulsing sound from the frame while it is unloading. This is considered normal and is not a cause for concern.</p> <p>If you hold the button in, the adjustment speed increases linearly, up to a preset maximum, until you release the button.</p>
<b>FINE JOG</b> (or <b>FINE POSITION</b> )	User control panel ( <a href="#">Figure 5</a> )	<p>Turn this thumbwheel for slow but accurate positioning of the piston within the hydraulic cylinder. <b>FINE JOG</b> allows you to set an accurate zero extension point, or to set a precise grip position for loading specimens. It can also be used to apply a controlled preload to specimens.</p>
<b>ZERO EXTENSION</b> (or <b>RESET GL</b> )	User control panel ( <a href="#">Figure 5</a> )	<p>Press this button to set the current position of the piston as the zero extension point (or gauge length) position. After setting the zero extension point, the piston returns to this position when:</p> <ul style="list-style-type: none"> <li>• The piston encounters a pre-set limit or event that instructs the piston to return to zero extension point</li> <li>• You press the <b>RETURN</b> button (with Bluehill software only)</li> </ul>

Table 10. Control functions. (Continued)

Control	Location	Description
<b>AT ZERO</b> Indicator (or <b>AT GL</b> Indicator)	User control panel (Figure 5)	This indicator illuminates when the piston is at the preset zero extension point. It will also illuminate when you press the <b>ZERO EXTENSION</b> button, which indicates that the current position of the piston is now the new zero extension point.
<b>POWER</b> Indicators	User control panel (Figure 5)	This <b>POWER</b> indicator illuminates when power to the 59 Series control unit is on. Associated with this are <b>FRAME STANDBY</b> and <b>FRAME READY</b> indicators. Certain subsystems, such as the load cell and its conditioner board, require a somewhat lengthy warm-up time. In <b>FRAME STANDBY</b> , power is supplied to these subsystems but not to the HPS (frame is disabled). In <b>FRAME READY</b> , the system supplies power to all subsystems including the HPS (frame is enabled). The system is ready for operation.
<b>SPECIMEN PROTECT</b> and Indicator	User control panel (Figure 5)	<b>SPECIMEN PROTECT</b> is an electronic function that protects test specimens and load cells from overload during test setup. Press this button to toggle this function on and off. The <b>ON</b> indicator shows when <b>SPECIMEN PROTECT</b> is on and off. The indicator blinks when <b>SPECIMEN PROTECT</b> is on. <b>SPECIMEN PROTECT</b> must be set up in the controlling software before it can be turned on (see software manual or on-line help for information on setting this feature). Also, it can only be turned on when the frame/HPS is enabled.
<b>START TEST</b>	User control panel (Figure 5)	Press this button to begin the test once all test parameters are set. Up and Down Arrow indicators show the type of test selected (Up indicates tension and Down indicates compression).
<b>STOP TEST</b>	User control panel (Figure 5)	Press this button to stop motion of the piston at the end of the test, if it has not already been programmed at the computer.
<b>RETURN</b>	User control panel (Figure 5)	This function is dependent on the controlling software; refer to the controlling software's On-line Help.
<b>LOAD</b>	59 Series control unit	A female 25-pin interface that connects the system's load cell to the transducer conditioning card.
<b>STRAIN 1</b>	59 Series control unit	A female 25-pin interface that connects an extensometer to an optional transducer conditioning card.
<b>STRAIN 2</b>	59 Series control unit	A female 25-pin interface that connects an extensometer to an optional transducer conditioning card. (Typically only required for transverse strain or other dual extensometer setups.)
<b>SERVICE Display</b>	59 Series control unit	Provides an indication of self-tests that are performed by the controls when the system is powered up and is also an indicator of system status. System status is normal when the <b>T</b> indicator is green and the <b>A</b> indicator is blinking red.

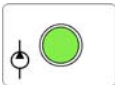

Figure 5. User control panel.

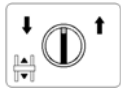

## Operation of HPS

The HPS is operated by controls on the HPS control box and the user control panel, and by functions within the controlling software. Methods to start and stop the HPS are provided in [Table 10](#) on page 29, “[Run a test](#)” on page 53 and “[Shut down the system](#)” on page 55.

When the HPS is on, the hydraulic cylinder should be positioned so that the piston is neither fully retracted nor fully extended. When the hydraulic cylinder is in either of these conditions, it is difficult for the 59 Series controls to maintain the position and the servo loop control could build up enough error to shut down the HPS.

## Mount fixtures

### Warning



**Always wear appropriate personal protective equipment when preparing, operating and maintaining this equipment. Personal protective equipment should include, but is not limited to, eye protection and head protection. Other types of personal protective equipment may also be needed. You must perform your own risk assessment and take appropriate measures to protect yourself from harm.**



*Use of lifting or handling equipment (i.e. overhead crane, hoist, etc.) may be necessary to lift and install testing accessories. Many testing accessories weigh in excess of 15 kgs (30 lbs) and may be difficult for operators to install and remove from the frame. All of these considerations are the responsibility of the customer.*

The frame is supplied with multiple bolt patterns for the mounting of specimen load trains and testing accessories. Some bolt patterns are designed for the mounting of specific standard Instron accessories or fixtures, while others are more general for the mounting of a wide range of standard Instron accessories or fixtures. Any bolt pattern can be used for the mounting of customer fixtures; appropriate adaptation may be necessary. The capacity of any load train or accessory may be limited by the capacity of the bolt pattern being used. Most bolt patterns can accommodate testing at full frame capacity. Refer to the Note below.

Details of the bolt patterns provided on your frame can be found on the General Assembly drawing that is located in the separately supplied “Reference Manual-Equipment”. General Assembly drawings are model specific; please be sure to refer to the appropriate drawing for your model and its configuration.



*Any bolt pattern that is six M10 x 1.5p tapped holes equally spaced on a 100 mm (3.937 in) bolt circle diameter can only accommodate low range tension testing up to 100 kN (22,500 lbs).*

## Mount tension fixtures

When it is desired to use other tension fixtures instead of the grip assemblies to grip a specimen, external tension fixtures (purchased separately) can be mounted to the tension crosshead and adjustable crosshead with proper adapters. Adapters can either be clamped in the grip assemblies or bolted to the crossheads using the bolt pattern provided on the top or bottom of each crosshead. For operation of the grip assemblies, refer to “[Operate grip assemblies](#)” on page 39.

## Mount compression fixtures

Compression fixtures (purchased separately) must be mounted to the bumper plate that is on the bottom of the adjustable crosshead and the compression table. Neither the bumper plate nor the compression table can be used to apply force directly to a specimen.

- **Upper compression fixtures** can be mounted to the bumper plate by one of two methods:
  - Bolt the fixture directly to the bumper plate using the bolt pattern provided in the bumper plate.
  - Use the setscrew and button hole provided in the bumper plate, see [Figure 6](#). The compression fixture must be equipped with a mounting button that fits into the button hole, as shown in [Figure 6](#). The setscrew is tightened against a recess in the holding button.
- **Lower compression fixtures** can be mounted to the compression table using the bolt pattern provided in the compression table. Depending on the compression fixture, it may not be necessary to secure the fixture to the table, refer to any instructions provided with your fixture.

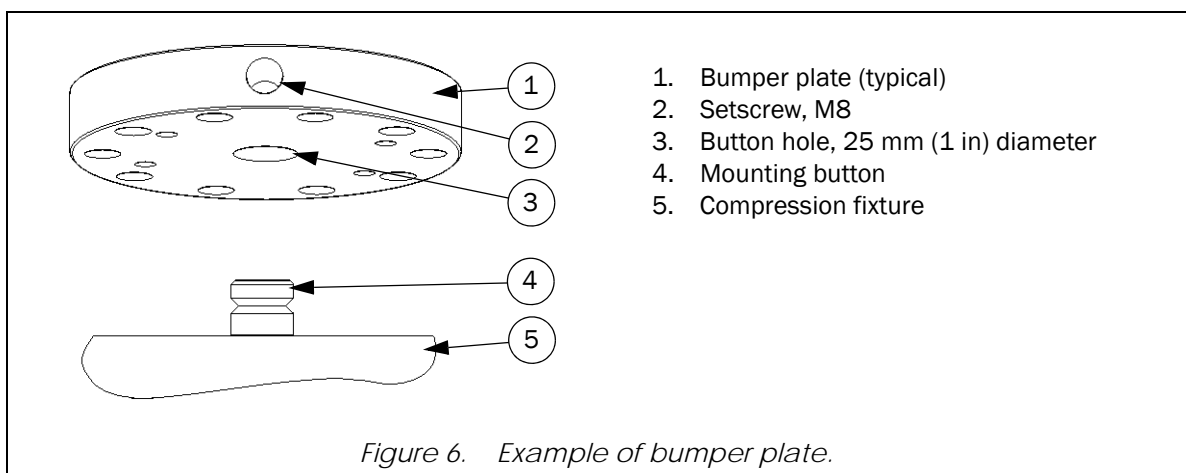

## Start the system



*This document presumes that customer training (by Instron service personnel) has been completed and that at least one procedure has been created in the controlling software.*

Before operating the system:

- Familiarize yourself with the operating features and controls described in these instructions and in all other accompanying documentation for the controlling software.
- Verify that your system voltage is compatible with your power supply.

Following is the recommended procedure for system startup:

1. Be sure that the proper rating of main power is supplied to all system components and that all electrical cables are plugged in.
2. If the system includes an expansion channel module, turn the power switch on the rear of the module to ON ( | ).
3. Turn the system disconnect switch to ON ( | ).
4. Turn the power switch on the rear of the 59 Series control unit to ON ( | ).
5. Turn on power to all peripheral equipment that interfaces with the computer system. This includes the monitor, printer, any digital calipers, etc. Turn on power to the computer's CPU (central processing unit).
6. Check the display on the user control panel. The display shows an hour glass while the controls perform self-tests. Once the hour glass goes away, start the controlling software.



*While the controlling software and control electronics are booting up, do not press any control buttons. This could cause a failure during some of the self-test routines.*

7. Open or create the desired test procedure in the controlling software.
8. Check that the lights on the front of the 59 Series control unit are illuminated as follows:
  - T indicator of the **SERVICE** display is green
  - A indicator of the **SERVICE** display is blinking red



*If the **SERVICE** display flashes the letter "F" during startup, it indicates that an error has occurred. Refer to "Troubleshooting" in the System Concepts Manual (supplied separately) for more information.*

9. Check that the lights on the user control panel are illuminated as follows:
  - **POWER** is green
  - **FRAME STANDBY** is red
  - **TEST STOPPED** is red
10. Calibrate the load cell and let the system warm-up for at least 15 minutes to assure system stability, then re-calibrate.



*A fifteen minute warm-up period is also necessary whenever a load cell is changed, or after the initial connection of a strain gauge. After the warm-up period, the load cell or strain gauge must be calibrated.*

## Change height of tension test opening

### Warning



Always wear appropriate personal protective equipment when preparing, operating and maintaining this equipment. Personal protective equipment should include, but is not limited to, eye protection and head protection. Other types of personal protective equipment may also be needed. You must perform your own risk assessment and take appropriate measures to protect yourself from harm.

---

The height of the tension test opening can be changed. To change the height, adjust the position of the adjustable crosshead, the tension crosshead, or both. Adjustment can only be done between tests, never during a test.

### Adjust the position of the adjustable crosshead

For procedure on moving the adjustable crosshead, see [“Adjustable crosshead control switch”](#) in [Table 10](#) on page [29](#).

### Adjust the position of the tension crosshead

The crosshead can be placed at any of the available notches in the notched columns (see [Table 5](#) on page [22](#) for available notch information). The tension crosshead is supported and secured by retaining rings that fit into the notches. The retaining rings are installed in the notches that are directly below the crosshead and then bolted to the crosshead.

### Equipment required

- A suitable **stable** platform such as a man-lift, stairs, or ladder. The platform must be of sufficient height so that the operator can reach the tension crosshead.
- Blocks of lumber to support the tension crosshead
- A 10 mm hex key (supplied)
- No lifting equipment is necessary, the adjustable crosshead can be used as an elevator

### Recommended procedure

1. [Start the system; see page 35](#). Start the HPS.
2. Adjust the adjustable crosshead so that blocks of lumber can be placed between the tension crosshead and the adjustable crosshead. Adjust the crosshead as follows:
  - a. **To lower the tension crosshead**, raise the adjustable crosshead so that it has enough travel to move downward.
  - b. **To raise the tension crosshead**, lower the adjustable crosshead so that it has enough travel to move upward.
3. Place the lumber between the adjustable crosshead and tension crosshead. Ensure that the tension crosshead is securely supported and level. If the tension crosshead does not remain level during adjustment, it can bind on the columns and become stuck.

4. Loosen the socket head cap screws (3, [Figure 7](#)) that secure each retaining ring (2) (use hex key). Remove the retaining rings from each column.
5. Adjust the adjustable crosshead until the lower surface of the tension crosshead is above the desired notch.
6. Place the retaining rings (2) into the notches and start the socket head cap screws (3) into the bottom of the tension crosshead. Lower the tension crosshead so that it is resting on the lower retaining rings. Tighten the socket head cap screws until seated plus one-quarter turn (use hex key).
7. Lower the adjustable crosshead and remove the lumber.
8. Normal operation can now resume.

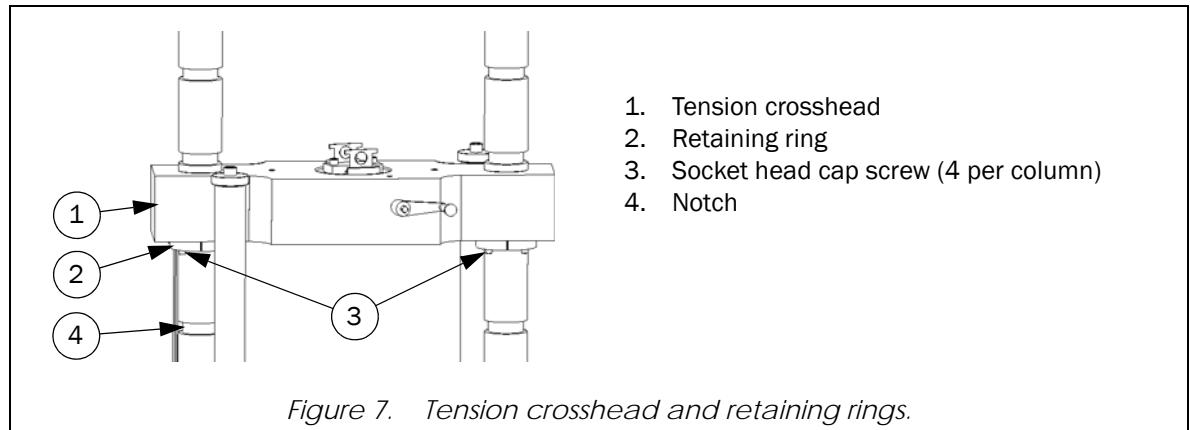

## Change height of compression test opening

### Warning

---

---



Always wear appropriate personal protective equipment when preparing, operating and maintaining this equipment. Personal protective equipment should include, but is not limited to, eye protection and head protection. Other types of personal protective equipment may also be needed. You must perform your own risk assessment and take appropriate measures to protect yourself from harm.

---

The height of the compression test opening can be changed. To change the height, adjust the position of the adjustable crosshead. Adjustment can only be done between tests, never during a test.

### Adjust the position of the adjustable crosshead

For procedure on moving the adjustable crosshead, see [“Adjustable crosshead control switch”](#) in [Table 10](#) on page [29](#).

# Operate grip assemblies

## Warning



Always wear appropriate personal protective equipment when preparing, operating and maintaining this equipment. Personal protective equipment should include, but is not limited to, eye protection and head protection. Other types of personal protective equipment may also be needed. You must perform your own risk assessment and take appropriate measures to protect yourself from harm.

## Warning



These grips are designed to grip specimens for testing. Therefore, an unavoidable pinching hazard exists. Make sure to read and understand all installation, removal and operating instructions before using the grips!

## Caution

Improper alignment of grip jaws and specimen will cause grip jaw damage and lead to grip pocket deformation. Be sure to read and obey the guidelines outlined on page 40 through page 41.

Both the tension and adjustable crossheads are equipped with grip assemblies that are designed to grip specimens for tensile testing. Frames can be purchased with either manual grip actuation (G1-style crossheads) or hydraulic grip actuation (G7-style crossheads).

Regardless of which type of grip actuation your frame is equipped with, the basic method of grip operation is the same. Each crosshead has a grip pocket with sloped sides (see [Figure 8](#) on page 45 and [Figure 9](#) on page 49). A matching pair of grip jaws fits into each grip pocket. The initial clamping force on the specimen is applied manually or hydraulically (as per crosshead style - G1 or G7), and then as load is applied to the specimen, the sloped sides of the grip pockets cause the grip jaws to tighten further on the specimen.

The grip jaws are purchased separately from the frame so that the appropriate jaw type can be chosen for your specific application. See "[Grip jaw selection](#)" on page 40 for some tips on selecting the appropriate grip jaws for your application.

**Use of Molykote type GN metal paste (high pressure lubricant) is necessary for proper operation of the grips. Instron recommends only this brand and type of high pressure lubricant. Use of any other lubricant risks damage to the grip components. This damage would not be covered under warranty.** A small amount of Molykote type GN metal paste is supplied with the frame, additional quantities can be purchased from Instron, contact your local Instron Services department as directed on page 19. **Be sure to apply the lubricant as specified in these instructions.**

## Warning



For G7-style crossheads - jaw carrier's jaw pocket and back of jaw face must be free from grease, oil or debris. Lubrication of these surfaces may result in damage to carrier and dangerous projectiles. Ensure dust cover is installed during tension testing.

For more information, refer to "[Lubrication Warning](#)" on page 69.

The following sections provide more details on grip jaw selection, grip jaw installation, and grip use. Refer to the appropriate section for your frame's crosshead style.

## Grip jaw selection

A specimen's size, shape and hardness must be considered when selecting the correct set of grip jaws to test that specimen. Improper selection of grip jaws can allow specimen slippage. Specimen slippage will cause excessive and premature wear of the grip jaw's teeth and further reduce the grip jaw's gripping ability.

In general, there are three criteria to consider when selecting a set of grip jaws:

- **Face profile:** The grip jaw's gripping face is made with a certain profile to fit the cross section of the specimen. The two most common face profiles are flat and vee. Flat-face grip jaws are used to test rectangular, or flat, specimens. Vee-face grip jaws are used to test round specimens, including rebar specimens. There are also grip jaws that have a semi-circular profile for testing cable-type specimens.
- **Tooth profile:** The surface of the gripping face is cut with a specific tooth profile to provide gripping ability. The tooth profile is defined by the cut of the teeth and the spacing of the teeth. The tooth cut is typically diamond or horizontal (also known as serrated). The tooth cut may affect the gripping effectiveness on some specimen types. The spacing of the teeth can be reported in either a pitch measurement (distance between rows of teeth) or the number of teeth per inch (TPI). A finer tooth (i.e. smaller pitch or larger TPI) typically works best for softer materials and smaller specimens. A coarse tooth (i.e. larger pitch or smaller TPI) typically works best for harder materials and larger specimens.
- **Specimen range:** Grip jaws are typically designed to test a specific range of specimen sizes. However, certain types of grip jaws, like those for cable-type specimens, are designed for a single size of specimen. It is very important that the size of specimen to be tested falls within the specimen range of the grip jaws. If the specimen is larger than the maximum or smaller than the minimum designed specimen range of the grip jaws, do not use those grip jaws. Also, once the specimen is installed in the grip jaws, the jaws should not extend out of the grip body. This includes the position of the grip jaws at the end of the test. If the grip jaws do extend more than 7 mm (0.25 in) at the end of the test, this would indicate the wrong size jaws are being used.

Instron offers a wide selection of grip jaws. For further information about the sizes and types of jaws available, see [Appendix A](#). You can also contact your regional Instron office or check our web site at [www.instron.com](http://www.instron.com) for assistance.

## Specimen guidelines

It is important to obey proper guidelines when preparing and testing a specimen:

- Do not attempt to test specimens that are of incorrect length:
  - For typical flat grip jaws and vee grip jaws, the specimen must be long enough to allow it to be gripped by at least 80 percent of the gripping face of **each** grip jaw. When less than 80 percent of the grip jaw's gripping face is used to clamp the specimen, the grip jaw will tip and cause damage to the grip pocket and internal grip components. Often the specimen may slip and cause damage to the face of the grip jaws.
  - For cable jaw inserts, the specimen must be long enough to allow it to be gripped by 100 percent of the gripping face of **each** grip jaw.
- Set the jaws firmly in contact with the specimen but do not hammer on the grip jaws or any other component of the grip assemblies to tighten the grip jaws.
- Watch for signs of specimen slippage and stop the test if slippage occurs.



- Be sure that the tooth pattern of the grip jaws is sufficient for the specimen's material type.

## General use guidelines

It is important to obey the following guidelines when using the grip assemblies:

- For frames with G1-style crossheads: Use sufficient filler plates.
- Be sure to properly maintain the grip assemblies as outlined in “[Grip assemblies](#)” on page 67.
- Keep grip components well lubricated as instructed in grip jaw installation procedures and in “[Grip assemblies](#)” on page 67. It is important that the lubricant on the grip components is always moist and is not dry, clumped or dirty.

## Caution

Use of Molykote type GN metal paste (high pressure lubricant) is necessary for proper operation of the grips. Instron recommends only this brand and type of high pressure lubricant. Use of any other lubricant risks damage to the grip components. This damage would not be covered under warranty.

## Warning



For G7-style crossheads - jaw carrier's jaw pocket and back of jaw face must be free from grease, oil or debris. Lubrication of these surfaces may result in damage to carrier and dangerous projectiles. Ensure dust cover is installed during tension testing.

For more information, refer to “[Lubrication Warning](#)” on page 69.

- Make sure the specimen is centered in the grip jaws.
- For frames with G1-style crossheads: Keep the grip jaws centered in the grip pocket by using an equal number of filler plates behind each grip jaw.
- Keep the ends of each pair of grip jaws even.
- Use the proper type of grip jaws for your specimen.
- DO NOT lubricate the gripping face of the grip jaws.

## Filler plate guidelines (G1-style crossheads only)



*Filler plates are used for G1-style crossheads only.*

Filler plates are an important part of the specimen gripping assembly. They assure the alignment of the specimen with the centerline of the grip pocket as well as axial alignment of the specimen. They also assure that the grip jaws do not extend beyond the crosshead (into the test space) when the specimen is gripped. Tests that are performed with the grip jaws extended beyond the crosshead will cause serious damage to the grip jaws and lead to grip pocket deformation. Grip jaw damage and grip pocket deformation caused by this type of use is NOT covered under warranty, see “[Specimen guidelines](#)” on page 40 for more information.

When installing filler plates, it is **imperative** to remember the following:

- Insert the filler plates into the grip pocket from the top of the crosshead so that they sit between the grip pocket and the sloped side of the grip jaw. The shoulders of the filler plate rest on the top of the crosshead and prevent the filler plate from falling through the crosshead.
- Install filler plates of the same total thickness behind each grip jaw. This assures alignment of the specimen with the centerline of the pocket as well as axial alignment of the specimen between the tension crosshead and adjustable crosshead.



*This does not apply to grip jaws that are made to test non-uniform specimens, such as angle grip jaws. In these cases, it is typically necessary to use filler plates of different thickness for each grip jaw so that proper specimen alignment can be achieved. The goal is to achieve alignment of the specimen with the centerline of the pocket as well as axial alignment of the specimen between the tension crosshead and adjustable crosshead.*

- Be sure enough filler plates are installed so that the narrow end of the grip jaws does not protrude beyond the crosshead when the specimen is gripped. **Failure to keep the narrow end of the grip jaws inside the pocket during a test will cause serious damage to the grip jaws and lead to grip pocket deformation.**
- Use enough filler plates so that at least the minimum gripping requirements are met; see “[Specimen guidelines](#)” on page 40. When the minimum gripping requirements are **NOT** met, the grip jaw will tip and cause damage to the grip pocket and other grip components. Often the specimen may slip and cause damage to the face of the grip jaws.

### Caution

Tests that are performed with the grip jaws extended beyond the crosshead will cause serious damage to the grip jaws and lead to grip pocket deformation. Use as many filler plates as required so that the narrow end of the grip jaws does not protrude beyond the crosshead when the specimen is gripped.

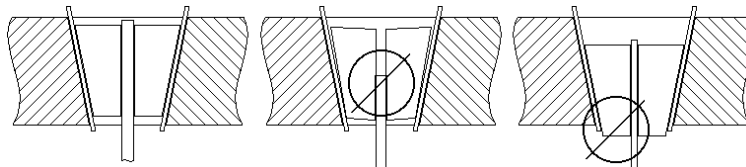

## Install grip jaws - G1-style crossheads

### Equipment and supplies required



All equipment must be supplied by the customer unless noted as “supplied”. For a list of equipment that was supplied with the system, refer to “Ancillary parts” on page 83.

- A suitable **stable** platform such as a man-lift, stairs, or ladder. The platform must be of sufficient height so that the operator can reach the tension crosshead.
- Hex keys, see [Table 11](#) on page 46 for sizes
- Molykote type GN metal paste

### Recommended procedure

#### Warning



Be careful **not** to injure fingers or hands when installing or removing grip jaws. Grip jaws typically weigh at least 5.9 kgs (13 lbs).



Grip jaws come as matched pairs. It is important that grip jaws are installed into the grip pockets as a matched pair. If they are not installed as matched pairs, the grips will not function. Matched pairs can be determined by placing the gripping teeth faces together as depicted below. Place each matched pair into the appropriate crosshead so that the rack teeth meet with the pinion.

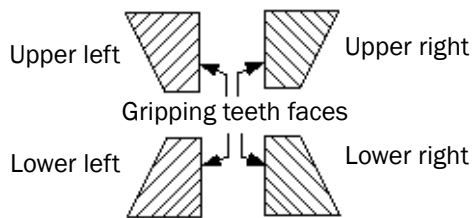

1. Remove the grip stop plate (5, [Figure 8](#)) from the top of the tension crosshead by removing the two socket head cap screws (6) that hold the plate to the crosshead (use hex key stated in [Table 11](#)).
2. Be sure a jaw retainer (7) is installed on each grip jaw as shown in [Figure 8](#) (use hex key stated in [Table 11](#)).
3. Lubricate the rear and sides (the smooth surfaces that come into contact with the grip pocket or filler plate) of each jaw with Molykote type GN metal paste. Apply lubricant liberally. **DO NOT apply lubricant to the specimen gripping surface.**

#### Caution

Use of Molykote type GN metal paste (high pressure lubricant) is necessary for proper operation of the grips. Instron recommends only this brand and type of high pressure

**lubricant. Use of any other lubricant risks damage to the grip components. This damage would not be covered under warranty.**



*It is important that the lubricant on the grip jaws, grip pocket and filler plates is always moist and is not dry, clumped or dirty.*

4. Insert the grip jaws into the grip pocket. See the NOTE above regarding matched grip jaw pairs. Be sure to insert the jaws properly.
5. Insert appropriate filler plates (shoulders will rest on top of crosshead) into the grip pockets from the top of the crosshead so that they sit between the sloped sides of the grip pocket and the sloped side of the grip jaw. See the [“Filler plate guidelines \(G1-style crossheads only\)”](#) on page 42 for important information on selecting and inserting filler plates.

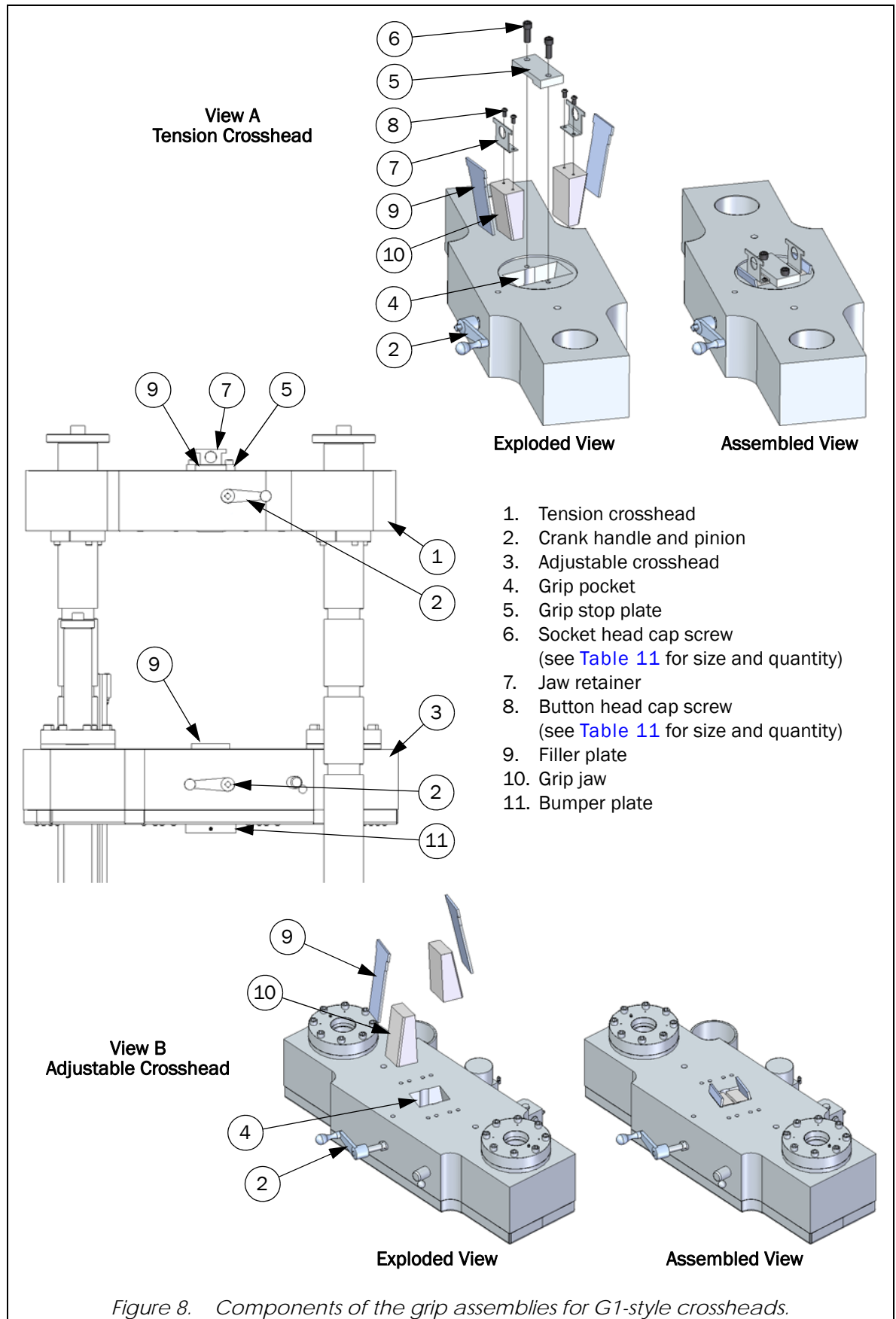

## Warning



Be careful not to injure fingers when inserting heavy filler plates.

## Caution

Grip jaws that extend beyond the crosshead during a test will cause serious damage to the grip jaws and lead to grip pocket deformation. Use as many filler plates as required so that the narrow end of the grip jaw does not protrude through the crosshead when the specimen is gripped.

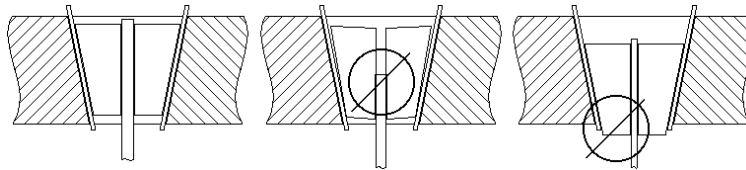

6. Open and close the grip jaws several times using the crank handle to check grip jaw action and ensure freedom of movement. If the grip jaws stick, remove them and apply more lubricant until the problem is resolved.
7. Install the grip stop plate on the tension crosshead and secure with the socket head cap screws (use hex key stated in [Table 11](#)).
8. Repeat steps [3](#) through [6](#) to install the remaining set of grip jaws into the adjustable crosshead. It is not necessary to remove the bumper plate from the bottom of the crosshead because the grip jaws can be inserted into the crosshead through the top of the grip pocket. When step [4](#) is reached, the grip jaws must be inserted one at a time into the pocket. Also, remember that the grip jaws must be inserted with the narrow end up.
9. The grip jaws are now ready to clamp a test specimen. See “[Insert specimen](#)” on page [52](#) for recommended procedures on inserting a specimen into the grip jaws. When performing repeated tests with the same set of grip jaws, it will be necessary to apply fresh lubricant to the grip jaws and filler plates as described in “[Lubricate the grip assemblies](#)” on page [67](#).



Filler plates can be inserted or removed from the tension crosshead with the grip stop plate in place.

Table 11. Specifications for grip stop plate and jaw retainer cap screws.

Frame Model	Grip Stop Plate SHCS (item <a href="#">6</a> , <a href="#">Figure 8</a> )			Jaw Retainer BHCS (item <a href="#">8</a> , <a href="#">Figure 8</a> )		
	Size	Quantity	Size of Hex Key Needed	Size	Quantity	Size of Hex Key Needed
1000HDX-G1	M16 x 45 mm	2	14 mm	3/8-16 x 0.75 in	4	7/32 in
1500HDX-G1	M20 x 90 mm	2	17 mm	1/2-13 x 0.75 in	4	5/16 in

## Remove grip jaws - G1-style crossheads

### Equipment required



All equipment must be supplied by the customer unless noted as “supplied”. For a list of equipment that was supplied with the system, refer to “[Ancillary parts](#)” on page 83.

- A suitable **stable** platform such as a man-lift, stairs, or ladder. The platform must be of sufficient height so that the operator can reach the tension crosshead.
- Hex keys (supplied), see [Table 11](#) on page 46 for sizes

### Recommended procedure

1. Remove the grip jaws from the tension crosshead:
  - a. Filler plates can be removed although this is not necessary.
  - b. Remove the grip stop plate (5, [Figure 8](#)) from the top of the tension crosshead by removing the two socket head cap screws (6) that hold the plate to the crosshead (use hex key stated in [Table 11](#)).
  - c. Turn the crank handle to place the grip jaws in the fully opened position.
  - d. Hold the crank handle and lift each grip jaw out of the grip pocket.
2. Remove the grip jaws from the adjustable crosshead (it is not necessary to remove the bumper plate (11) from the bottom of the crosshead; the grip jaws can be removed one at a time from the top of the grip pocket):
  - a. Remove all filler plates from the grip pocket.
  - b. Rotate the crank handle to close the grip jaws until the grip jaws clear the pinion (grip jaws will not extend any further). This will raise the upper portion of the grip jaws out of the grip pocket.
  - c. Hold the grip jaws in place with the crank handle and grasp one of the grip jaws.
  - d. Continue to hold the grip jaw and rotate the crank handle to lower the remaining jaw; this provides clearance for removal of the first grip jaw.
  - e. Lift the first grip jaw out of the grip pocket.
  - f. Rotate the crank handle to raise the remaining grip jaw.
  - g. Grasp the grip jaw and remove it from the grip pocket.

## Install grip jaws - G7-style crossheads

### Warning



For G7-style crossheads - jaw carrier's jaw pocket and back of jaw face must be free from grease, oil or debris. Lubrication of these surfaces may result in damage to carrier and dangerous projectiles. Ensure dust cover is installed during tension testing.

For more information, refer to “[Lubrication Warning](#)” on page 69.

## Equipment and supplies required



All equipment must be supplied by the customer unless noted as “supplied”. For a list of equipment that was supplied with the system, refer to “[Ancillary parts](#)” on page [83](#).

- A suitable **stable** platform such as a man-lift, stairs, or ladder. The platform must be of sufficient height so that the operator can reach the tension crosshead.
- 4 mm hex key (supplied)
- Molykote type GN metal paste

## Recommended procedure

### Warning

---



Factory clamping speed is set to 4 mm/sec (0.16 in/sec) closure rate or less. A hazard to operators may be created if the clamping speed is adjusted faster than 4 mm/sec (0.16 in/sec).

Use caution if adjusting the clamping speed of the jaws. The jaws can be adjusted to move very quickly. Keep fingers and hands free of jaws.

---

### Warning

---



Be careful **not** to injure fingers or hands when installing or removing grip jaws. Grip jaws typically weigh at least 5.9 kgs (13 lbs) each.

---

Each grip jaw has an alignment hole to assure proper orientation in the grip pocket and proper teeth alignment. Left and right grip jaws are typically interchangeable.

1. [Start the system; see page 35](#). Start the HPS.
2. Use the grip controls to fully open the jaw carriers (see [Table 12](#) on page [50](#) for operation of grip controls). The jaw carriers must be fully open.
3. Lift a grip jaw into the grip pocket and align the alignment hole (3, [Figure 10](#)) in the grip jaw to the alignment pin (4) in the jaw carrier.
4. Place the locating boss (2) into the jaw carrier recess (5).
5. Tighten the retainer setscrew (8) against the retainer button (7) through the access hole on the front guide plate (7, [Figure 9](#)) (use 4 mm hex key).

### Warning

---



The tightness of the retainer setscrew (14, [Figure 9](#) on page [49](#)) should be checked after 50 consecutive tests are performed with the same set of grip jaws. The retainer setscrews can vibrate loose and allow the grip jaws to fall out of the jaw carriers.

---

6. Repeat for each grip jaw.



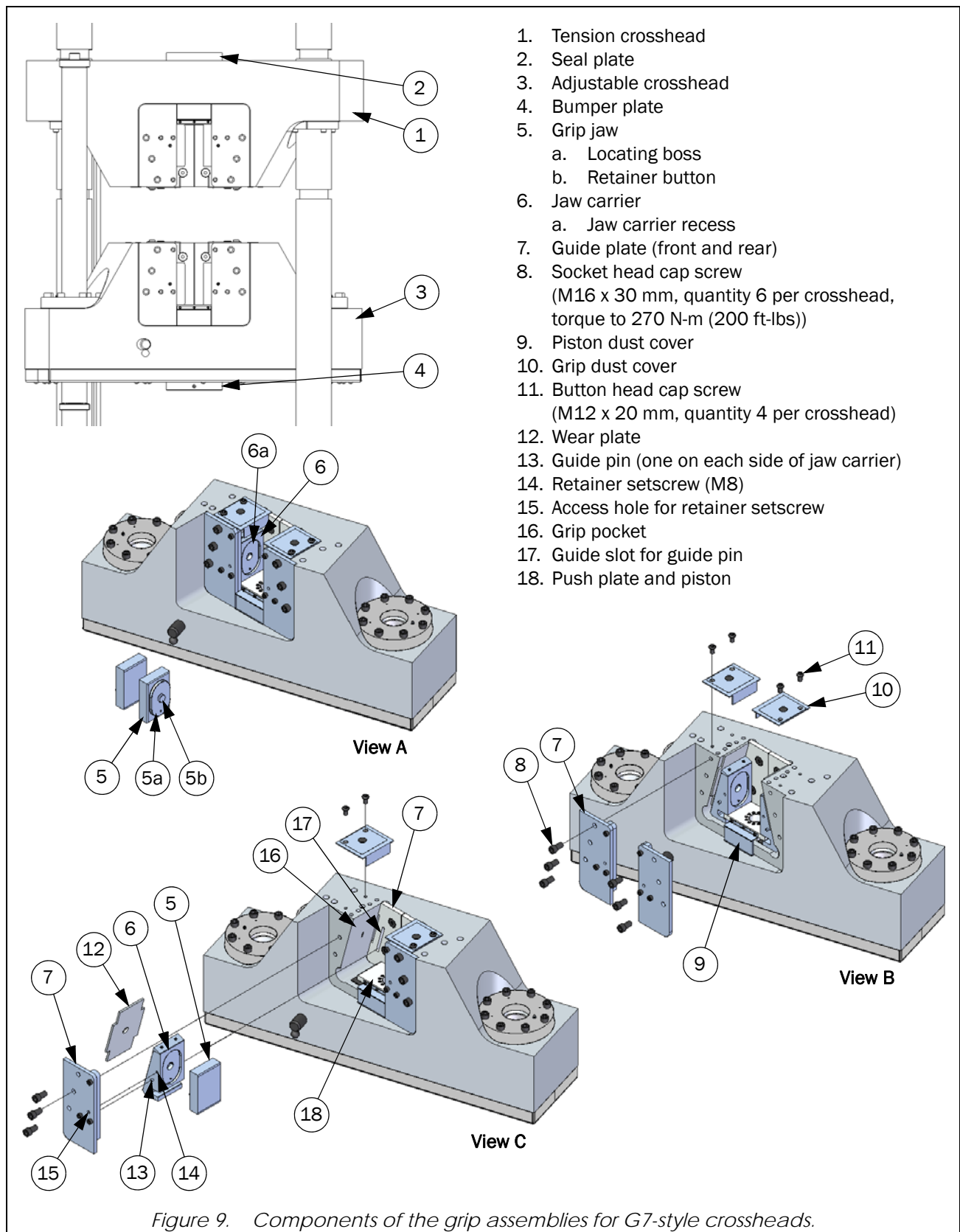

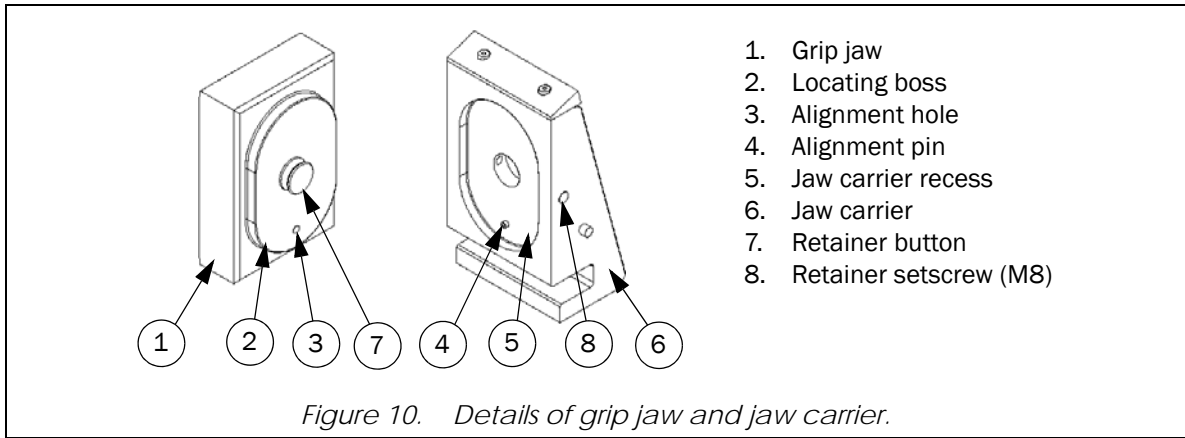
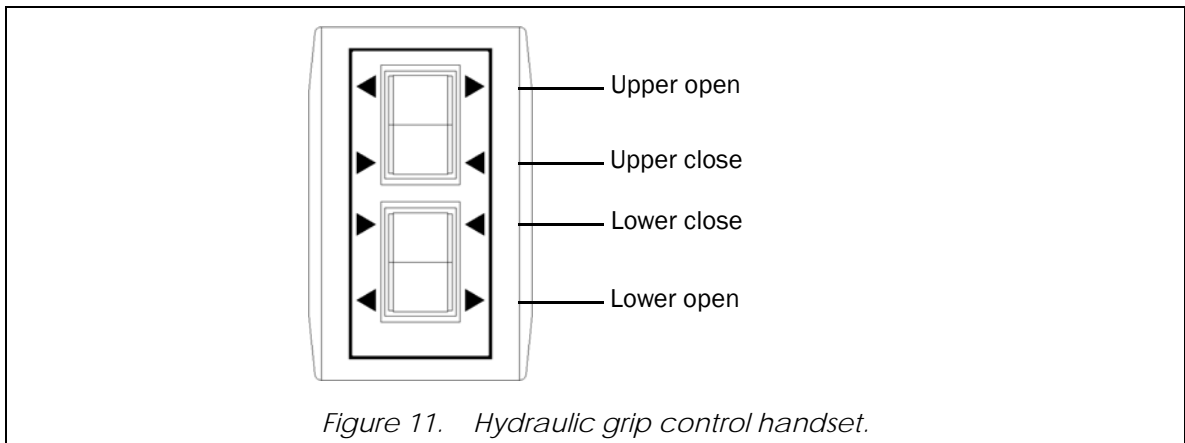

Table 12. Function of grip controls (see Figure 11 on page 50.

Function	Switch Type	Use
<b>Open</b>	Momentary - returns to <b>Neutral</b> when released	Unclamp grip jaws
<b>Close<sup>1</sup></b>	Latch - remains at <b>Close</b> when released	Clamp grip jaws, test in progress
<b>Neutral</b>	N/A (no switch activated)	No test in progress, system idle

1. If a switch is in the **Close** position and main power is lost to the frame\*, the grips will stop and hold their current position; also the switch will remain latched in the **Close** position but will be put into **Neutral** mode (i.e. will not function). When power is restored to the frame, the grips and the grip controls will remain in this hold/neutral condition until the switch is reset. The switch must be reset to restore grip function. To reset the switch, move it to the **Neutral** position and then operate as desired.

\* For conditions that result in loss of main power to the frame, see “Loss of power” on page 56.



## Remove grip jaws - G7-style crossheads

### Warning



For G7-style crossheads - jaw carrier's jaw pocket and back of jaw face must be free from grease, oil or debris. Lubrication of these surfaces may result in damage to carrier and dangerous projectiles. Ensure dust cover is installed during tension testing.

For more information, refer to “[Lubrication Warning](#)” on page [69](#).

### Equipment and supplies required



All equipment must be supplied by the customer unless noted as “supplied”. For a list of equipment that was supplied with the system, refer to “[Ancillary parts](#)” on page [83](#).

- A suitable **stable** platform such as a man-lift, stairs, or ladder. The platform must be of sufficient height so that the operator can reach the tension crosshead.
- 4 mm hex key (supplied)

### Recommended procedure

1. Use the grip controls to fully open the grip jaws. The grip jaws must be fully open.
2. Loosen the retainer setscrew (6) through the access hole on the front guide plate (7, [Figure 9](#)) (use 4 mm hex key). Only loosen the setscrew enough to release the grip jaw.
3. Remove the grip jaw from the grip pocket.
4. Repeat for each grip jaw.

## Insert specimen

### Warning

---



These grips are designed to grip specimens for testing. Therefore, an unavoidable pinching hazard exists. Make sure to read and understand all installation, removal and operating instructions before using the grips!

---

Be sure to use a specimen of sufficient length to meet the minimum gripping requirements; see “[Specimen guidelines](#)” on page 40. With this in mind, take the following steps to insert a specimen into the grips:

1. Make sure both upper and lower grip jaws are open (unclamped).
2. Insert and center the specimen into the grip jaws of the upper grip assembly and clamp the grip jaws firmly in contact with the specimen. Be sure that the specimen is inserted according to the minimum gripping requirements outlined in “[Specimen guidelines](#)” on page 40. Let go of the specimen and remove your hand from the frame.
3. Raise or lower the adjustable crosshead as necessary so that the specimen extends the proper distance into the grip pocket of the adjustable crosshead. Be sure that the specimen is inserted according to the minimum gripping requirements outlined in “[Specimen guidelines](#)” on page 40.
4. Clamp the grip jaws firmly in contact with the specimen.



*For frames with G7-style crossheads: When a specimen is gripped hydraulically, the gripping force at each end often causes a compression load in the specimen. This load may be noticeable on the indicator. If this is objectionable, we suggest either setting up and using the specimen protect feature in the controlling software or using the **JOG UP** control button on the user control panel to move the loading unit in the load direction as the grip jaws are closed on the specimen.*

5. **For frames with G1-style crossheads:** Remove the crank handle from both the upper and lower pinions. If the crank handle is not removed, damage to the pinion and the rack teeth of the grip jaws can occur.
6. The specimen is now ready for testing.

### Warning

---



Be sure to keep fingers out of the frame while the crosshead is moving or a test is in progress.

---

# Run a test

## Warning



Always wear appropriate personal protective equipment when preparing, operating and maintaining this equipment. Personal protective equipment should include, but is not limited to, eye protection and head protection. Other types of personal protective equipment may also be needed. You must perform your own risk assessment and take appropriate measures to protect yourself from harm.



*This information is NOT test specific, it is only intended to assist you in the general aspects of running a test. If you are testing to a specific standard or society specification (ASTM, ISO, EN, BS, etc.), those specifications should be obeyed with regard to number of tests run, specimen specifications, fixturing, inserting specimens and all other aspects of materials testing.*



*This document presumes that customer training (by Instron Service Engineer) has been completed and that at least one procedure has been created in the controlling software.*



*Refer to the supplied software manual for specific information about the controlling software. The following is only a general description of the necessary steps to run a test.*

Ensure that the following conditions are met before a test is run:

- The **LOAD** channel is calibrated.
- The **STRAIN** channel is calibrated if you are using an extensometer.
- You have reviewed the manuals for the controlling software and are familiar with the on-line help system that accompanies the software.
- Know the specific procedures to set up and run a test.
- The load transducer, grips and fixtures are appropriate for your test.

Following is the recommended procedure to run a test on a specimen:

1. If the system is not currently turned on, complete "[Start the system](#)" on page 35.
2. Verify that the setup and test parameters are reasonable and correct for your test.
3. Ensure that the displays on the user control panel illuminate.
4. Check that the frame is enabled.
5. Start the HPS. The **FRAME READY** indicator will illuminate. Immediately check the position of the piston within the hydraulic cylinder; the piston should be positioned so that it is neither fully retracted nor fully extended. If the piston is in either of these conditions, the servo loop control could build up enough error to shut down the HPS. Use the jog controls to move the piston if necessary - typically a separation of 6 mm (0.25 in) is sufficient.
6. Determine the required test opening and stroke needed to complete the desired test. Be sure to take into consideration the effective length of the fixtures that will be used, the length or height of the specimen, and the expected change in length or height that the specimen will undergo during the test.

7. Determine if it is necessary to make any adjustments to the frame configuration to attain the required test opening that was determined in step 6:
  - a. For tension tests: Raise or lower the tension crosshead as necessary - see “[Adjust the position of the tension crosshead](#)” on page 36. Also, raise or lower the adjustable crosshead as necessary using the adjustable crosshead control switch.
  - b. For compression tests: Raise or lower the adjustable crosshead as necessary using the adjustable crosshead control switch.
8. Install the desired specimen fixtures into the test space using adapters and alignment couplings as necessary. If using the grip assemblies to perform a tension test, install the grip jaws - see “[Operate grip assemblies](#)” on page 39.
9. Balance the load, if necessary.
10. Install the specimen into the fixtures as specified by your test method.
11. Install extensometry, strain gauges, etc. (if applicable).
12. Reset the zero extension point, if necessary.
13. Start the test.



*The test can be stopped at any time by using either the **STOP TEST** button on the user control panel or the **END TEST** button in the controlling software. This does not shut down the HPS unless the end test action in the software is set up to perform that task.*



*If it is necessary at any time to shut down the HPS, press the **DISABLE FRAME** button in the controlling software.*

14. As the test is running, the controlling software dynamically displays the data that is being collected or calculated for graphing and results. Also, the user may be prompted to perform some operation, such as remove an extensometer. When the operation has been performed, click the appropriate button to continue the test.
15. When the test is complete, the system will automatically stop the test as determined by the test procedure.
16. Remove the specimen and prepare the system for another test (as applicable).



*If the frame will sit idle between tests, press the **DISABLE FRAME** button in the controlling software to shut down the HPS. For added precaution, engage the **Emergency Stop** button to ensure that the HPS can not be inadvertently started. Release the **Emergency Stop** button when ready to run the next test. Once the HPS is running, immediately check the position of the piston within the hydraulic cylinder; the piston should be positioned so that it is neither fully retracted nor fully extended. Use the jog controls to move the piston if necessary - typically a separation of 6 mm (0.25 in) is sufficient.*

---

## Shut down the system

It is recommended that the system as a whole (frame, control unit, HPS, computer system, peripherals, etc.) be shut down at the end of each working day or anytime it will sit idle for long periods of time. The procedure to shut down the system is as follows:

1. Remove any specimen from the fixtures and jog the hydraulic cylinder so that the piston is fully retracted. Also, refer to “[Loss of power](#)” on page 56.
2. Press the **DISABLE FRAME** button in the controlling software to shut down the HPS.
3. Engage the **Emergency Stop** button.
4. Exit the controlling software and any other software that is running. Shut down the Windows Operating System.
5. Turn off all peripheral equipment.
6. Turn the power switch on the rear of the 59 Series control unit to OFF ( **O** ).
7. Turn the system disconnect switch to OFF ( **O** ).

If the frame will sit idle between tests, press the **DISABLE FRAME** button in the controlling software to shut down the HPS. For added precaution, engage the **Emergency Stop** button to ensure that the HPS can not be inadvertently started. Release the **Emergency Stop** button when ready to run the next test. Once the HPS is running, immediately check the position of the piston within the hydraulic cylinder; the piston should be positioned so that it is neither fully retracted nor fully extended. Use the jog controls to move the piston if necessary - typically a separation of 6 mm (0.25 in) is sufficient.

## Loss of power

If at any time main power is lost to the frame (due to the disconnect switch being turned off, **Emergency Stop** being engaged, power loss at the customer power supply, or complete power loss to facility), gravity will cause the frame to go to its natural resting state, i.e. the piston will retract into the hydraulic cylinder. To impede this process, the system is equipped with a valve that closes at loss of system power and prohibits oil leakage from the hydraulic cylinder. However, it can not stop 100% of oil leakage and thus the hydraulic cylinder will drift very slowly. Drift is slow enough that a noticeable amount of drift may be seen if system power remains off over an extended period (i.e. several days). Even with this very slow drift rate, multiple pinching hazards may exist on the frame (depending on accessories mounted in the test space) and personal injury is still possible. Also, any equipment in the tension test space may be damaged. If possible, remove any specimens from the frame.

If power can not be restored to the frame and it is necessary to retract the piston into the hydraulic cylinder, contact your local Instron Services department as directed on page [19](#) for a solution.

### Warning

---



On loss of power, immediately remove hands and arms from the frame to avoid personal injury.

---

### Caution

---

On loss of power, any equipment in the test space may be damaged, particularly extensometers. It is always good practice to keep equipment that is not currently in use out of the test space.

It can be verified that the piston is fully settled to the bottom of the cylinder by the following:

- Measure the distance between the bottom of the compression table and the top of the base plate. This distance should be **less than** the following:
  - 1000HDX: 127 mm (5 in)
  - 1500HDX: 141 mm (5.563 in)
- If power has been off for at least 5 minutes.
- Visually observe the loading unit for movement.



# Chapter 4

## Maintenance

---

- General maintenance recommendations ..... 57
- Preventative maintenance schedule ..... 57
- Make daily checks of system ..... 59
- Remove and install console covers ..... 60
- Electronics ..... 61
- Frame ..... 61
- Grip assemblies ..... 67
- Hydraulic power supply (HPS) ..... 76
- Ancillary parts ..... 83
- Consumable parts ..... 85
- Spare and replacement parts ..... 85

---

### Warning



Always wear appropriate personal protective equipment when preparing, operating and maintaining this equipment. Personal protective equipment should include, but is not limited to, eye protection and head protection. Other types of personal protective equipment may also be needed. You must perform your own risk assessment and take appropriate measures to protect yourself from harm.

---

## General maintenance recommendations

Only the maintenance procedures outlined in these instructions should be performed by the customer or their representative. All other maintenance and repairs should be performed by Instron Service personnel only.

## Preventative maintenance schedule

Table 13 outlines a recommended preventative maintenance schedule for system components.

Table 13. Recommended preventative maintenance schedule.

Frequency	Component	Maintenance Task
Daily:	System	<ul style="list-style-type: none"> <li>• Make daily checks of system; see page 59.</li> </ul>
	Grip assemblies	<ul style="list-style-type: none"> <li>• Clean external surfaces and check operation of grip assemblies; see page 67.<sup>1</sup></li> </ul>

Table 13. Recommended preventative maintenance schedule. (Continued)

Frequency	Component	Maintenance Task
Daily or after every 50 consecutive tests:	Grip assemblies of G7-style crossheads	<ul style="list-style-type: none"> <li>The tightness of the retainer setscrew should be checked daily or after 50 consecutive tests are performed with the same set of grip jaws. The retainer setscrews can vibrate loose and allow the grip jaws to fall out of the jaw carriers. See “Install grip jaws - G7-style crossheads” on page 47.</li> </ul>
Weekly or after every 150-300 tests <sup>2</sup> :	Grip assemblies	<ul style="list-style-type: none"> <li>Lubricate the grip assemblies; see page 67.<sup>1</sup></li> </ul>
Monthly or after every 2000 tests <sup>2</sup> :	Grip assemblies	<ul style="list-style-type: none"> <li>Clean and inspect grip components; see page 69.<sup>1</sup></li> </ul>
Monthly:	System	<ul style="list-style-type: none"> <li>Visually inspect <b>all</b> hoses (exposed and hidden) and around the base of the frame and HPS for signs of oil leakage. Investigate any abnormal or excessive leakage and correct appropriately.</li> </ul>
	Frame	<ul style="list-style-type: none"> <li>Check non-painted surfaces; see page 61.</li> </ul>
	HPS	<ul style="list-style-type: none"> <li>Check level of oil in reservoir and add oil as necessary. Refer to “Add oil to reservoir” on page 76.</li> </ul>
Biannually (or once every 1000 hrs. of operation) <sup>2</sup> :	System	<ul style="list-style-type: none"> <li>Inspect the hydraulic hoses; see page 81.</li> <li>Inspect the cables; see page 61.</li> </ul>
	Frame	<ul style="list-style-type: none"> <li>Inspect the adjustable crosshead; see page 62.</li> <li>Inspect the hydraulic cylinder; see page 65.</li> </ul>
	HPS	<ul style="list-style-type: none"> <li>Check the oil cleanliness; see page 76.</li> </ul>
	HPS	<ul style="list-style-type: none"> <li>Clean the air filter; see page 82.<sup>3</sup></li> </ul>
	Electronics	<ul style="list-style-type: none"> <li>Clean the fans; see page 61.<sup>3</sup></li> </ul>
Annually (or once every 2000 hrs. of operation) <sup>2</sup> :	System	<ul style="list-style-type: none"> <li>Verify/Calibrate system.</li> </ul>
	HPS	<ul style="list-style-type: none"> <li>Change the air breather filter; see page 81.</li> <li>For <b>special</b> operating conditions where oil temperature is continuously between 60 and 80 deg. C (140 and 176 deg. F) - Change the oil; see page 79.</li> </ul>
	Frame	<ul style="list-style-type: none"> <li>Lubricate the adjustable crosshead; see page 62.</li> </ul>
Biennially (or once every 4000 hrs. of operation) <sup>2</sup> :	HPS	<ul style="list-style-type: none"> <li>For <b>normal</b> operating conditions where oil temperature is continuously below 60 deg. C (140 deg. F) - Change the oil; see page 79.</li> </ul>
Every 5 years:	System	<ul style="list-style-type: none"> <li>Replace high pressure hydraulic hoses; see page 82.</li> </ul>
Every 7 years:	System	<ul style="list-style-type: none"> <li>Replace low pressure hydraulic hoses; see page 82.</li> </ul>

- The frequency listed here for maintenance of the grip assemblies is only a recommendation. The correct frequency for your grips is heavily dependent on how often the grips are used, the environmental conditions in which the grips are used, and the type of specimens that are tested. Frequent use or dirty environments may require more frequent maintenance, while less frequent use or clean laboratory conditions could require less. We recommend beginning with the frequency listed here and then adjusting this frequency as experience dictates. Also, the lower grip may require more frequent cleaning than the upper grip, simply because it will tend to collect more dirt and debris.
- Whichever is soonest.
- The frequency listed here is only a recommendation. The correct frequency for your system is heavily dependent on the environmental conditions in which your system is used. Dirty environments may require a more frequent interval, while clean laboratory conditions could require less. We recommend beginning with the frequency listed here and then adjusting this frequency as experience dictates.

## Make daily checks of system

Before operating the system each day, a general check of the system is highly recommended. Performing a good general check on a daily basis is an important part of preventative maintenance. It also allows the operator to become familiar with the system, and with what is considered normal behavior and normal appearance. Once familiar with the system, operators will be more likely to notice any abnormalities that could indicate problems, or potential problems, with the system. Before operating the system each day:

- Check that the frame is square and not out of alignment. This can be a simple visual check. Stand away from the frame and check that all horizontal components (i.e. the compression table, adjustable crosshead and tension crosshead) are parallel with each other and aligned vertically. Also check that all vertical components (i.e. all columns) are parallel with each other and aligned horizontally. Misalignment indicates that a larger problem exists.
- Check that all testing fixtures (compression plates, bend fixtures, external tension accessories, adapters, etc.) are free of dirt, damage and deformation. Any fixture with damage or deformation should be corrected before use!
- Check the tightness of the socket head cap screws in the retaining rings that support the tension crosshead on the columns.
- Check that power is adequately supplied to the electronics. Start up the system and check all indicator lights on the user control panel, HPS controls and 59 Series control unit. Check that the lights are not too bright or too dim, and that they don't flicker. If any of these conditions exist, this could indicate a problem with the power supply in the 59 Series control unit or with system main power (customer supply).
- Visually inspect the following for signs of oil leakage. Investigate any leakage and correct appropriately. It is not necessary to remove any covers from equipment unless an oil leak is found.
  - Any **exposed** hydraulic hoses - this may indicate leakage from loose connections or from damaged hoses.
  - Around the base of the frame - this may indicate leakage from internal hydraulic connections or from the hydraulic cylinder itself.
  - Around the base of the HPS - this may indicate leakage from internal hydraulic connections.Remove covers as necessary to investigate any oil leakage; see ["Remove and install console covers"](#) on page 60. If an oil leak is suspected from the hydraulic cylinder, see ["Inspect the hydraulic cylinder"](#) on page 65 for guidance.
- Check that all cables are free of wear and chafing, have adequate slack to prevent excessive strain on connectors, and have tight connections.

If any of these checks reveal a potential problem, the problem should be investigated and corrected **before** the system is operated. For assistance in troubleshooting the system, contact your local Instron Services department as directed on page 19.

## Remove and install console covers

To perform any maintenance on the HPS it is necessary to remove the rear cover from the console. Loosen and remove the six or seven (depending on model) M6 button head cap screws (2, [Figure 12](#)) from the rear cover (1). Be careful of the electrical wires to the fan. If necessary, the wires can be disconnected at their connections. When installing the cover, tighten all cap screws until fully seated. The only equipment required is a 4 mm hex key (supplied).

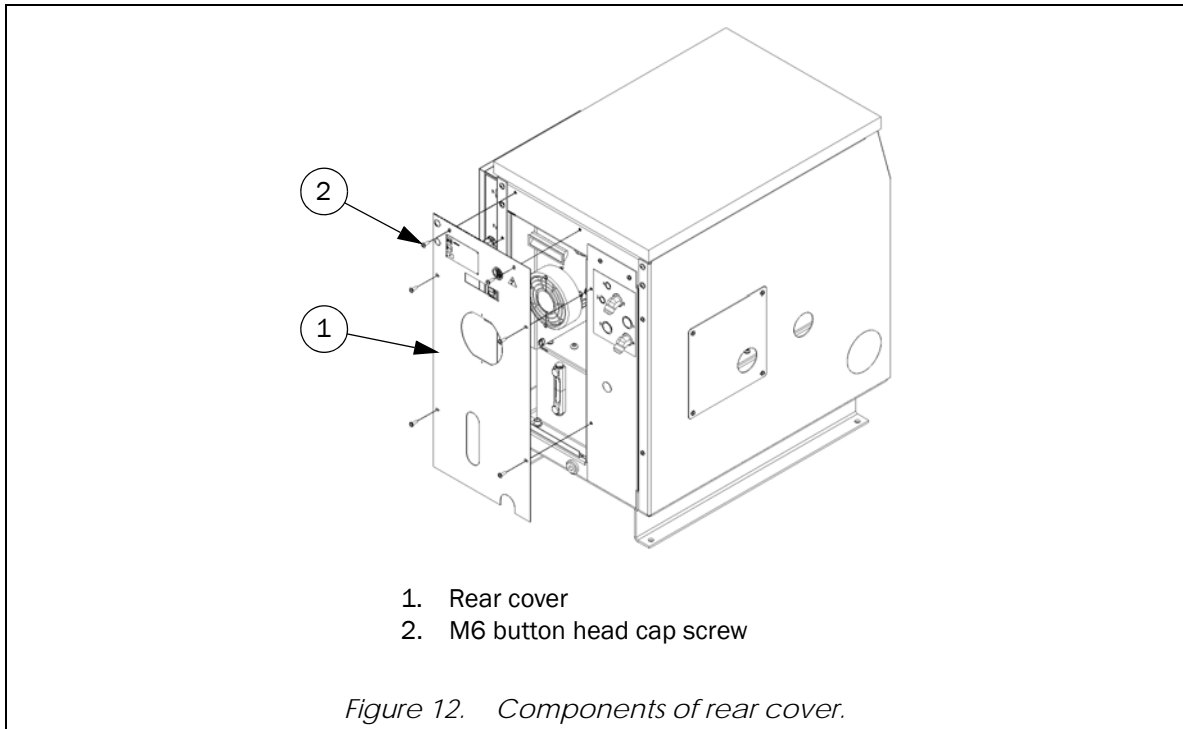

---

# Electronics

## Clean the fans

The fan opening of the 59 Series control unit and the computer system's CPU should be cleaned at the frequency stated in the [“Preventative maintenance schedule”](#) on page 57. The fan opening for the 59 Series control unit is on the rear of the unit. Use a vacuum to remove dust and dirt from the grill of the fan and the fan filter.

## Fuses

The system is equipped with one or more fuses. These fuses should only need replaced when they are blown. Refer to Chapter 4 of the System Concepts Manual (supplied separately) for more information on troubleshooting for a blown fuse.

## Inspect the cables

Cables should be inspected at the frequency stated in the [“Preventative maintenance schedule”](#) on page 57. Check the following:

- Inspect all cables for loose connections. This includes power cable and transducer cable connections at the frame and at the HPS. Tighten any loose connections that you may find.
- Inspect all cables for deterioration. Check for abrasions, cuts, etc. Replace cables as necessary.

If you notice any problems resulting from this inspection, contact your local Instron Services department as directed on page 19 for immediate assistance.

# Frame

## Warning



---

Always wear appropriate personal protective equipment when preparing, operating and maintaining this equipment. Personal protective equipment should include, but is not limited to, eye protection and head protection. Other types of personal protective equipment may also be needed. You must perform your own risk assessment and take appropriate measures to protect yourself from harm.

---

## Check non-painted surfaces

All non-painted frame surfaces (i.e. compression table, crosshead surfaces, etc.) should be checked for signs of dryness or corrosion and kept covered with a thin film of light machine oil to prevent corrosion. The oil should be applied at the frequency stated in the [“Preventative maintenance schedule”](#) on page 57.

## Adjustable crosshead

### Inspect the adjustable crosshead

Operation of the adjustable crosshead should be checked at the frequency stated in the “[Preventative maintenance schedule](#)” on page 57. To check operation, use the adjustable crosshead controls to operate the adjustable crosshead through its entire range of motion. Check for binding and abnormal noise. The crosshead should move smoothly. If you notice any problems resulting from this inspection, contact your local Instron Services department as directed on page 19 for immediate assistance.

### Lubricate the adjustable crosshead

The backlash eliminator assemblies, screw columns and adjustable crosshead drive chain must be lubricated at the frequency stated in the “[Preventative maintenance schedule](#)” on page 57. Proper lubrication prevents wear and promotes good operation of these components. Each frame is equipped with two backlash eliminator assemblies and screw columns. A backlash eliminator assembly is located at the junction of each screw column in the adjustable crosshead. The backlash eliminator assemblies have nipple-style grease fittings for easy lubrication. All threads of the screw columns must have a coating of grease at all times. The drive chain is in an enclosure on the bottom of the adjustable crosshead.

### Equipment and supplies required



All equipment and supplies must be supplied by the customer unless noted as “supplied”. For a list of equipment that was supplied with the system, refer to “[Ancillary parts](#)” on page 83.

- A nipple-style grease gun - Either a hand operated or pneumatic grease gun can be used. For frames with G7-style crossheads, DO NOT use the grease gun that is supplied for lubrication of the grip assemblies.
- A 5 mm hex key (supplied)
- A flat screwdriver - Only needed for frames with screw column covers (supplied with frames that have G7-style crossheads)
- Solvent or diesel fuel - Only needed to clean the grease from the screw columns if the existing grease on the screw columns has dried to a paste
- A paint brush
- Clean towels, rags, or similar
- Appropriate lubricants - refer to [Table 14](#) for recommended greases - equivalent greases can be substituted

Table 14. Recommended lubricants for adjustable crosshead components.

Location	Recommended Lubricant
Backlash Eliminators (grease fittings) Screw Columns	<ul style="list-style-type: none"> <li>• Dow Corning, Molykote BR2 Plus<sup>1</sup></li> <li>• Chevron, Delo Heavy Duty Moly 3% EP2</li> <li>• Allegheny Petroleum, Altra LCM EP#2</li> </ul> <p>Note: Other suitable greases can be used. A suitable grease is any multipurpose extreme pressure NLGI grade #2 lithium complex grease with 3% Molybdenum Disulfide.</p>

Table 14. Recommended lubricants for adjustable crosshead components.

Location	Recommended Lubricant
Crosshead Drive Chain	<ul style="list-style-type: none"> <li>• Petroleum based oil (motor oil) SAE30</li> <li>• Roller Chain Lubricant</li> </ul> <p>Note: Use only petroleum based oils, such as good quality motor oil, with a viscosity equivalent to SAE30 or specifically petroleum based roller chain lubricants. Do not use penetrating lubricants, such as WD-40, to lubricate or clean the chain.</p>

1. Can be purchased from Instron. See [Table 17](#) on page [85](#) for part numbers.

## Recommended procedure

1. Be sure the system is shut down.
2. Locate the components:
  - The grease fittings for the backlash eliminator assemblies are on the rear of the adjustable crosshead. There is one fitting for each backlash eliminator assembly, see [Figure 13](#).
  - For frames that are purchased with the optional screw column covers (as shown in [Figure 13](#)) it will be necessary to loosen or remove one of the clamps from each section of the covers. The column covers can then be collapsed and moved out of the way. It may be helpful to secure the upper section with string (or similar) to keep it out of the way.
  - The drive chain is accessible through a small cover on the back of the adjustable crosshead, see [Figure 13](#).
3. Lubricate the backlash eliminator assemblies:
  - a. Clean the grease fitting of each backlash eliminator assembly of any dust or debris.
  - b. Connect the fitting of the grease gun to one of the grease fittings.
  - c. Apply grease until grease is forced out around the backlash eliminator assembly.
  - d. Remove the grease gun fitting.
  - e. Remove any excess grease.
  - f. Repeat steps [b](#) through [e](#) for remaining backlash eliminator assembly.
4. Lubricate the screw columns:
  - a. Clean any dust, dirt or debris that may be present on the exposed threads. If the grease has dried to a paste, the old grease should be removed using solvent or diesel fuel before applying new grease. Use caution to prevent solvent from contacting painted surfaces or skin. Also use cautionary measures, such as placing towels around the top of the backlash eliminator assembly, to minimize the amount of solvent that gets into the backlash eliminator assembly. Clean both screw columns.
  - b. Use a paint brush to paint the grease onto all exposed screw column threads. Be sure to grease thoroughly. Grease both screw columns.
  - c. Remove yourself and any equipment from the frame. In particular, remove any towels from around the screw columns.

## Warning



Entanglement hazard exists. It is necessary to start up the system in order to complete lubrication. Remove all body parts from the frame before starting the system. Be sure that all equipment is removed from the frame.

- d. Start the system; see page 35.
- e. Raise or lower the adjustable crosshead to allow access to the unexposed section of the screw columns. This would be the portions that are covered by the adjustable crosshead.

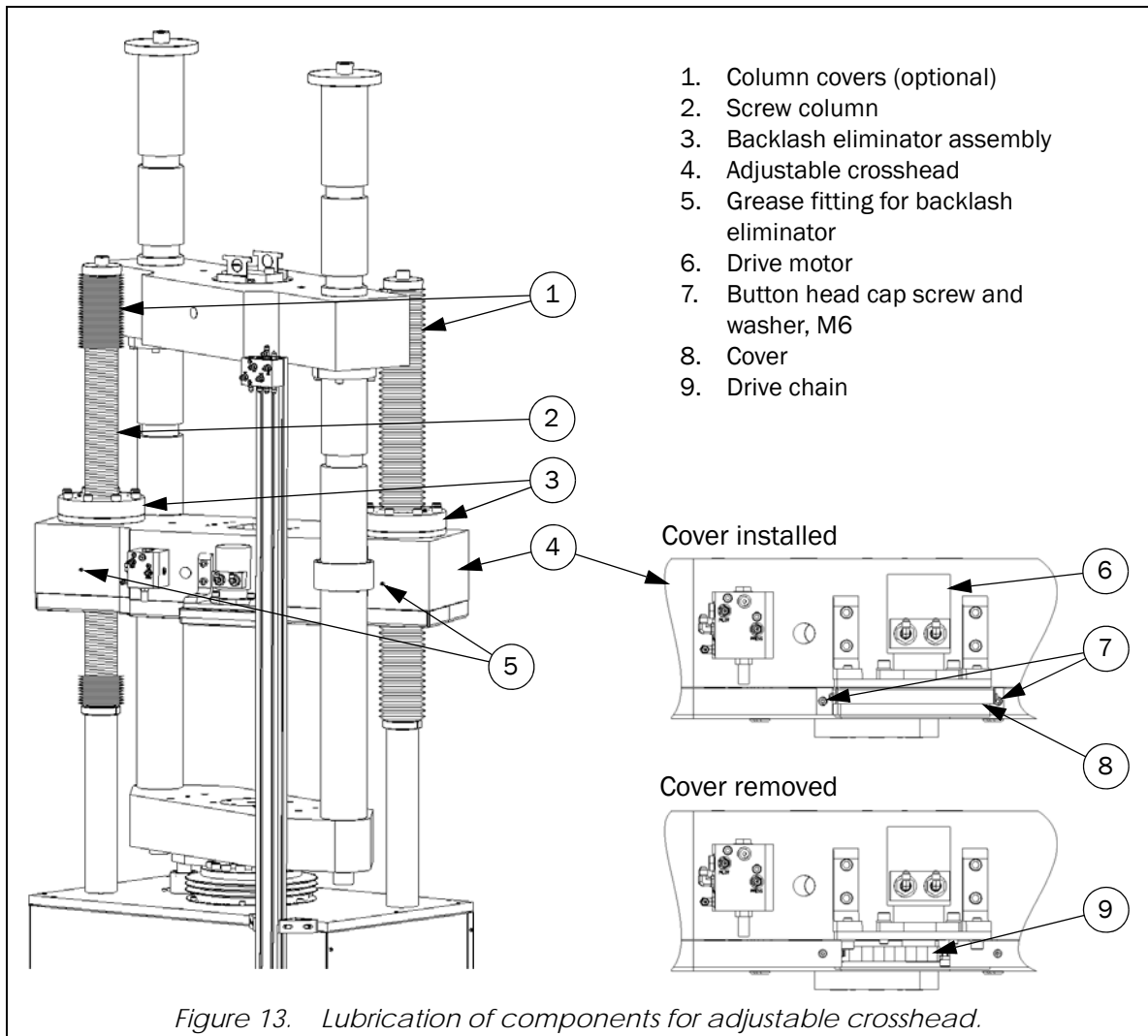

- f. Shut down the system; see page 55.
- g. Repeat steps a and b on this newly exposed area of each screw column.
- h. For frames with the optional screw column covers, replace the column covers and tighten the clamp adjusting screw.
- i. Remove any equipment from the frame. In particular remove any towels from around the screw columns and any towels that were used during the cleanup process.



5. Lubricate the drive chain:
  - a. Loosen and remove the M6 button head cap screws and washers (7) from the cover (8) (use 5 mm hex key).
  - b. Remove the cover.
  - c. Lubricate the exposed section of the drive chain (9) (use paint brush).
  - d. Remove yourself and any equipment from the frame. In particular, remove any towels from around the screw columns.

## Warning



Entanglement hazard exists. It is necessary to start up the system in order to complete lubrication. Remove all body parts from the frame before starting the system. Be sure that all equipment is removed from the frame.

- e. [Start the system; see page 35.](#)
- f. Raise or lower the adjustable crosshead until a new section of drive chain is exposed.
- g. [Shut down the system; see page 55.](#)
- h. Repeat steps [c](#) through [g](#) until all sections of the drive chain have been lubricated.
- i. Install the cover that was removed in step [b](#).

## Inspect the hydraulic cylinder

The hydraulic cylinder should be inspected at the frequency stated in the “[Preventative maintenance schedule](#)” on page [57](#). Perform the following:

- Check movement of the piston in the hydraulic cylinder. Use the jog controls to operate the hydraulic cylinder through its entire range of motion. Check for binding and abnormal noise. The piston should move smoothly. Also, watch the load display in the controlling software. The load reading should remain fairly constant as the piston moves. Increases and decreases in the load reading could indicate that the piston is binding. If you notice any problems resulting from this inspection, contact your local Instron Services department as directed on page [19](#) for immediate assistance.
- Inspect the hydraulic cylinder for signs of oil leakage. The frame is equipped with a drain bottle to catch any oil that may leak from the hydraulic cylinder. The drain bottle is located on the left rear corner of the frame base. To access the drain bottle, remove the left cover from the frame base (see [Figure 14](#)). There should be no oil or a very minimal amount of oil in the bottle. If there is a significant amount of oil in the bottle (i.e. more than 30 mL (1 oz)), then the seal of the hydraulic cylinder is possibly damaged. You should contact your local Instron Services department as directed on page [19](#) for immediate assistance. If it should ever be necessary to empty the bottle, detach the drainage hose from the bottle and dispose of the oil appropriately. Be sure to attach the hose firmly when putting the bottle back on the frame.

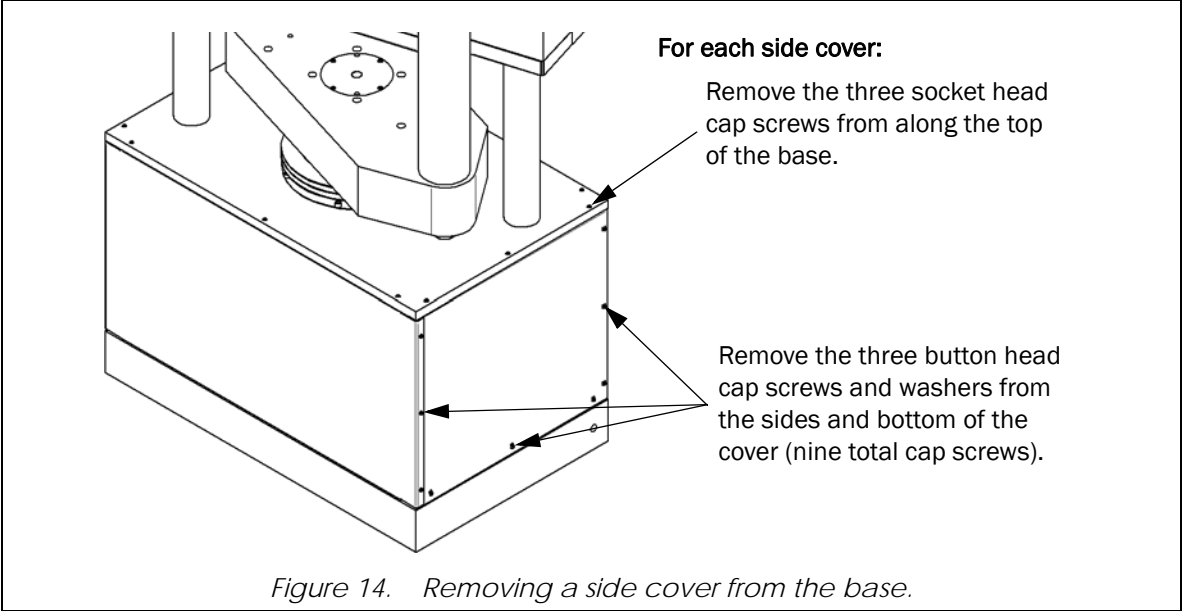

# Grip assemblies

## Warning



Always wear appropriate personal protective equipment when preparing, operating and maintaining this equipment. Personal protective equipment should include, but is not limited to, eye protection and head protection. Other types of personal protective equipment may also be needed. You must perform your own risk assessment and take appropriate measures to protect yourself from harm.

The grip assemblies must receive regular care to prevent damage to grip pockets and grip components. In general, the frequency guidelines stated in the “[Preventative maintenance schedule](#)” on page 57 will give you a good indication of when and how to care for your grips. However, if your system is used in a very dirty environment or to test specimens that create debris at fracture, then those frequencies may need increased.

## Clean external surfaces and check operation of grip assemblies

The external surfaces of the grip assemblies should be cleaned of dirt and debris at the frequency stated in the “[Preventative maintenance schedule](#)” on page 57. The external surfaces include the exposed portions of the grip pockets and the face of the grip jaws. This cleaning is particularly important for the lower grip body because it will tend to collect more dirt and debris.

Open and close the grip jaws as necessary to make it easier to reach all surfaces. For frames with G1-style crossheads (closed pockets), it may be easier to remove the grip jaws from the crosshead. Various methods can be used to remove the dirt and debris: a rag or cloth, a brush (medium sized, with medium-stiff bristles is recommended), or a vacuum.

For specimens that create a lot of debris at fracture (such as rebar), it will probably be necessary to increase the cleaning frequency to every few tests instead of only once a day. Also, it can be very helpful to use some type of protective cover around the specimen and over the grip pocket to reduce the amount of debris that falls into the grip pocket. This cover can be made of paper or cardboard with a specimen-sized hole cut out in the middle. For a really simple cover, use a paper or Styrofoam plate. Just make sure that the cover does not interfere with testing or operation of the grip assemblies.

Once the grip assemblies have been cleaned, check the operation of the grip assemblies with a set of grip jaws installed. Open and close the grip jaws several times and check for binding and abnormal noise. The grip jaws should move smoothly. For frames with G1-style crossheads, be sure that the grip jaws stay aligned with each other as they are opened and closed. If they do not, this indicates a damaged pinion that probably needs to be replaced. Refer to “[Inspect and replace the pinion - G1-style crossheads](#)” on page 75.

## Lubricate the grip assemblies

The grip assemblies must be properly and sufficiently lubricated to operate properly. Grip components should be lubricated at the frequency stated in the “[Preventative maintenance schedule](#)” on page 57 - **be sure to read Footnote 1 in this section. Use of Molykote type GN metal paste (high pressure lubricant) is necessary for proper operation of the grips. Instron recommends only this brand and type of high pressure lubricant. Use of any other lubricant risks damage to the grip components. This damage would not be covered under warranty.** A small amount of Molykote type GN metal paste is supplied with the frame, additional quantities can be purchased from Instron, contact your local Instron Services department as directed on page 19. Lubrication procedures are different depending on whether the

frame is equipped with G1-style crossheads or G7-style crossheads. **Be sure to apply the lubricant as specified in these instructions.**

## Caution

---

Use of Molykote type GN metal paste (high pressure lubricant) is necessary for proper operation of the grips. Instron recommends only this brand and type of high pressure lubricant. Use of any other lubricant risks damage to the grip components. This damage would not be covered under warranty.



*It is important that the lubricant on the grip components is always moist and is not dry, clumped or dirty.*

**For frames with G1-style crossheads:** Remove the grip jaws from the crossheads as outlined in “[Remove grip jaws - G1-style crossheads](#)” on page 47. Add fresh lubricant to the grip jaws and reinstall them as outlined in “[Install grip jaws - G1-style crossheads](#)” on page 43. It is not necessary to remove existing grease before applying fresh grease.

## Warning

---



For G7-style crossheads - jaw carrier's jaw pocket and back of jaw face must be free from grease, oil or debris. Lubrication of these surfaces may result in damage to carrier and dangerous projectiles. Ensure dust cover is installed during tension testing.

For more information, refer to “[Lubrication Warning](#)” on page 69.

**For frames with G7-style crossheads:** The jaw carriers are lubricated through grease fittings located in the crosshead next to each jaw (see [Figure 19](#) on page 74); a grease gun and two grease cartridges are supplied with the grips and additional quantities can be purchased from Instron. The grease fittings apply grease to the rear and sides of the jaw carriers. Use the following procedure to lubricate each jaw carrier. You will need a soft cloth and the grease gun loaded with a grease cartridge.

1. Use the grip controls to fully open the grip jaws.
2. Remove the grease fitting plug (15, [Figure 19](#)) from the dust cover to access the grease fitting.
3. Using the soft cloth, wipe away any dirt or specimen debris from the grease fitting of the jaw carrier that you want to lubricate.
4. Attach the grease gun nozzle to the grease fitting.
5. Pump the gun an appropriate amount of times until grease seeps out between the grip body and jaw carrier. Begin with five pumps of the gun and increase or decrease the amount as experience dictates.
6. Detach the grease gun nozzle from the fitting.



*New grease guns may be difficult to detach from the fitting. If this occurs, simply loosen the nozzle from the grease gun hose to release the spring in the nozzle. It may be necessary to pry nozzle from fitting; use care not to damage nozzle or grips. This condition should decrease as the grease gun is broken in.*

7. Repeat as necessary to lubricate the remaining jaw carriers.
8. Re-install all grease fitting plugs.

## Lubrication Warning

### Warning



Jaw carrier's jaw pocket and back of jaw face must be free from grease, oil or debris. Lubrication of these surfaces may result in damage to carrier and dangerous projectiles. Ensure dust cover is installed during tension testing.

The surfaces between the four jaw carrier pockets and jaw faces **MUST NOT** be lubricated. The design of the grip assembly relies on friction between the jaw carrier pocket and the jaw faces.

Jaw carrier pocket surfaces and jaw faces must be cleaned before installation to remove any oil, dirt, dust and other debris. Use a solvent such as mineral spirits or other degreasing agent and wipe clean with a cloth.

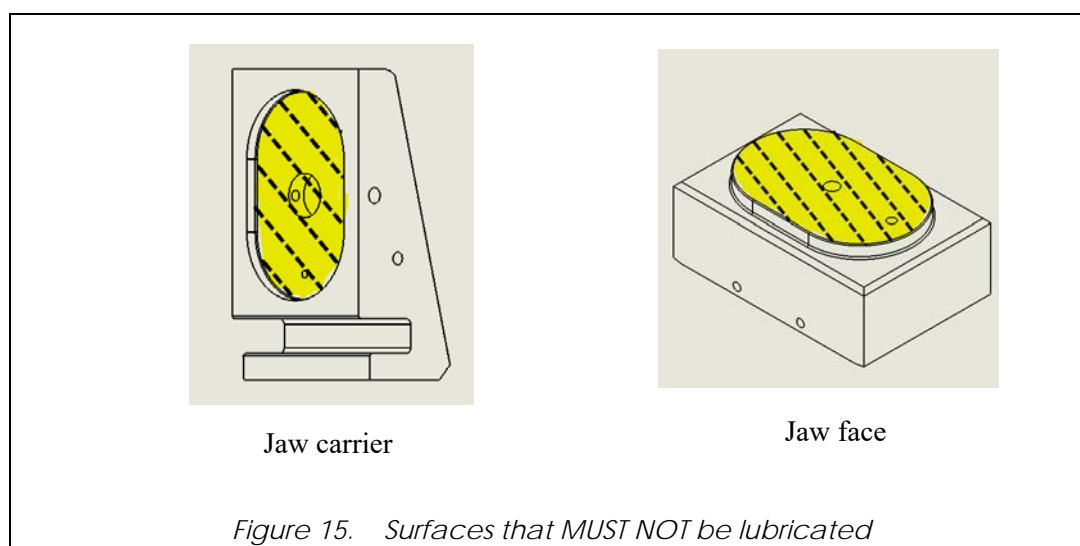

Figure 15 on page 69 shows the surfaces on the jaw carrier and jaw face that **MUST NOT** be lubricated.

Figure 16 on page 70 shows an overall view of the grip with the jaw carrier and jaw faces alongside. The shaded areas **MUST NOT** be lubricated.

Figure 16 on page 70 also shows the dust covers in position. Although not intended or designed as a safety component, these covers help reduce the energy of any broken jaw carrier pieces. Make sure they are installed before performing any tension tests.

## Clean and inspect grip components

The grip pockets and all grip components should be cleaned and inspected at the frequency stated in the “[Preventative maintenance schedule](#)” on page 57, or more frequently if needed - **be sure to read Footnote 1** of this table.

### Equipment and supplies required

- A suitable **stable** platform such as a man-lift, stairs, or ladder. The platform must be of sufficient height so that the operator can reach the tension crosshead.

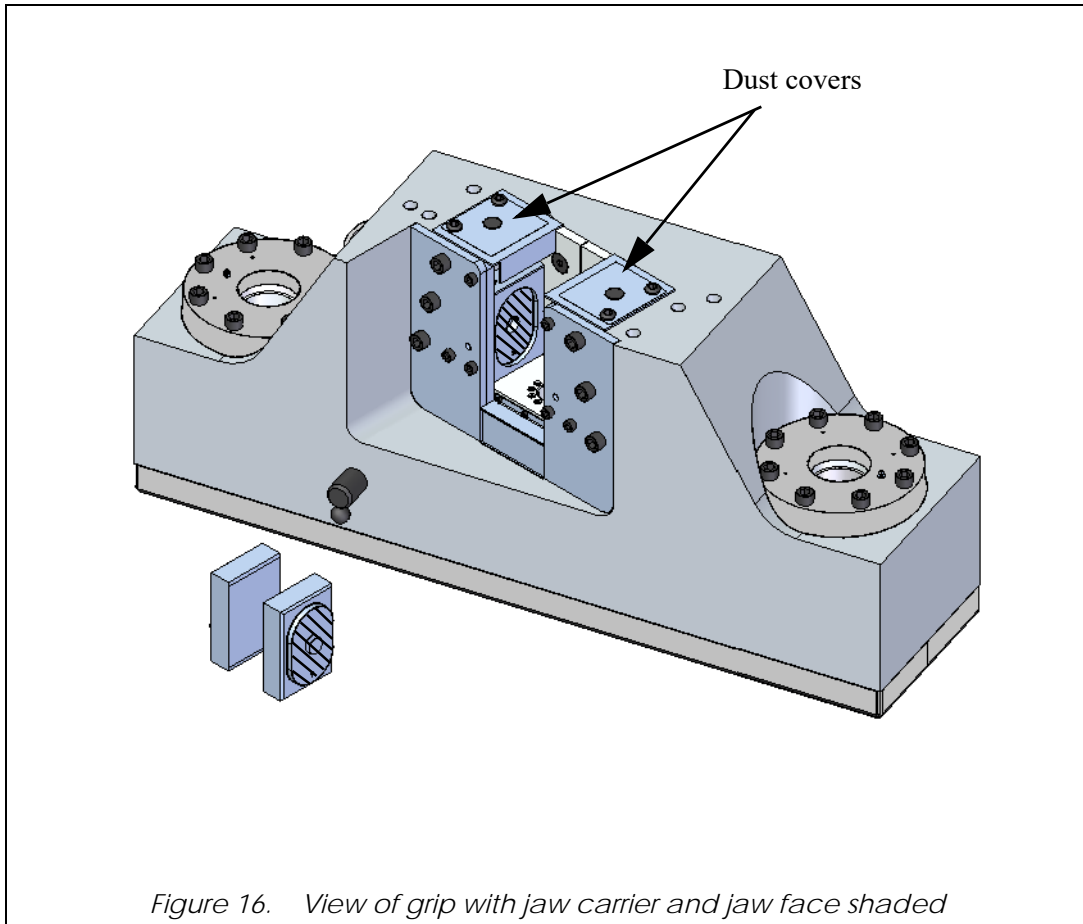

All equipment and supplies must be supplied by the customer unless noted as “supplied”. For a list of equipment that was supplied with the system, refer to [“Ancillary parts”](#) on page 83.

- **For frames with G1-style crossheads:** Hex keys, see [Table 11](#) on page 46 for sizes
- 4 mm, 8 mm and 10 mm hex keys (supplied)
- 14 mm hex bit socket (supplied)
- torque wrench with 1/2 in square drive and capacity of 200 N-m (150 ft-lbs)
- Molykote type GN metal paste

## Recommended procedure

1. Clean and inspect grip jaws, this includes **all** sets of grip jaws, not just the ones in use:
  - a. Remove grip jaws from each grip pocket, refer to either [“Remove grip jaws - G1-style crossheads”](#) on page 47 or [“Remove grip jaws - G7-style crossheads”](#) on page 51 depending on the crosshead style of your frame.
  - b. Clean lubricant from all sets of grip jaws.

## Warning



For G7-style crossheads - jaw carrier's jaw pocket and back of jaw face must be free from grease, oil or debris. Lubrication of these surfaces may result in damage to carrier and dangerous projectiles. Ensure dust cover is installed during tension testing.

For more information, refer to “[Lubrication Warning](#)” on page 69.

- c. Inspect each grip jaw for damage:
  - **For frames with G1-style crossheads:** Check the rack teeth. If the rack teeth are broken such that smooth operation of the pinion is prevented, the grip jaw should be replaced.
  - **For frames with G7-style crossheads:** The locating boss on the rear of the grip jaw fits into the recess of the jaw carrier with tight tolerance. Dirt or damage in either area may cause them to be press-fit together during testing. If damage is found along the edge of the locating boss, the edge can be filed smooth.
  - Check the gripping teeth. If more than 50% of the gripping teeth are broken or damaged, the grip jaw should be replaced.
  - Check the entire grip jaw for cracks. If any cracks are found, the grip jaw should be replaced.
2. **For frames with G1-style crossheads:** Clean and inspect filler plates:
  - a. Remove filler plates from each grip pocket.
  - b. Clean lubricant from all filler plates.
  - c. Inspect filler plates for damage. Check for bent corners, nicked or galled surfaces, and warping. If a damaged filler plate can be repaired so that it is flat and the shoulders will still support the filler plate in the crosshead, then the filler plate may be repaired and re-used. If damage is severe enough to prohibit repair, then the filler plate must be replaced.
3. **For frames with G1-style crossheads:** Clean and inspect grip stop plate and bumper plate:
  - a. Remove grip stop plate from the top of the tension crosshead (refer to step 1 of “[Install grip jaws - G1-style crossheads](#)” on page 43).
  - b. Remove bumper plate from bottom of adjustable crosshead (use 10 mm hex key) and then remove adapter plate from bottom of adjustable crosshead (use 14 mm hex key for 1000HDX frames, or 17 mm hex key for 1500HDX frames).
  - c. Clean any lubricant from all plates.
  - d. Inspect all plates for cracks. If cracks are found, replace the component.
4. **For frames with G7-style crossheads:** Clean and inspect guide plates:
  - a. Remove the guide plates from the front of each grip pocket (use 14 mm socket and wrench with a 1/2 in square-drive).
  - b. Clean lubricant from all guide plates. This includes the guide plates on the rear of the grip pocket; it is not necessary to remove them.
  - c. Inspect all guide plates for damage. Check for sharp edges, deformed corners and warping. Also check all guide slots for damage - this could indicate a bent or broken guide pin (see step 7). Sharp edges and deformed corners can typically be filed smooth. If damage is severe or inhibits motion of the jaw carriers, the guide plates should be replaced.
5. **For frames with G7-style crossheads:** Clean and inspect wear plates:
  - a. Remove wear plates from each grip pocket.
  - b. Clean lubricant from the wear plates.

- c. Inspect wear plates for damage. Check for broken plates, gouged or worn surfaces, bent edges, and warping (see [Figure 18](#) for an example of a damaged wear plate). **If a wear plate has ANY damage, replace it.** It is very important that the wear plates be free from damage. If damaged wear plates are used, damage to other grip components will occur!
  - d. It is highly recommended that the wear plates are replaced anytime the jaw carriers are replaced (see step 7).
6. **For 1500HDX-G1 frames:** Visually inspect the top surface of the filler plate wear strips. (See [Figure 17](#). Two wear strips are located on the top of each crosshead along the edge of the grip pocket. They provide a hardened surface for the shoulders of the filler plates.) Check for broken plates, gouged or worn surfaces, bent edges, and warping. If a damaged wear strip can be repaired so that it is flat and will not interfere with the filler plate in the crosshead, then the wear strip may be repaired and re-used. If damage is severe enough to prohibit repair, then the wear strip must be replaced.

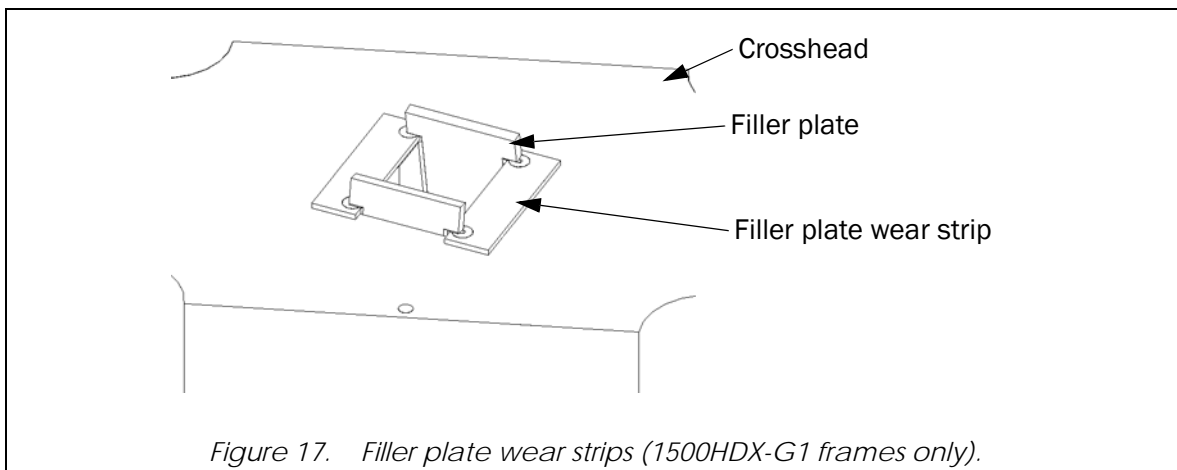

7. **For frames with G7-style crossheads:** Clean and inspect jaw carriers:
- a. Remove jaw carriers from each grip pocket.



- b. Clean lubricant from the jaw carriers.
- c. Inspect jaw carriers for damage:
  - Check the recess of each jaw carrier for dirt or damage. The locating boss of the grip jaw fits into the recess with tight tolerance. Dirt or damage in either area may cause them to be press-fit together during testing. If damage is found along the edge of the recess, the edge can be filed smooth.
  - Check for any cracks, particularly around the upper portion of the recess. If any cracks are found, the jaw carrier must be replaced.
  - Check for excessively shiny or worn surfaces (blackening is worn off of surface). This could indicate a poor fit or presence of debris. Investigate the cause of the wear and correct any problems. Some wear is expected with normal use.
  - Check for gouged surfaces. This could indicate that there is or has been debris between surfaces and that the interval for cleaning should be more frequent, see Footnote 1 of Table 13 on page 57. This could also indicate that the grip dust covers (13, Figure 19) are not installed correctly. (Continued use with debris between surfaces may cause binding of the jaw carriers and lead to further damage or wear. If gouge is not severe, the area can be filed smooth. If gouge can not be smoothed, the jaw carriers should be replaced.
  - Check for bent or broken front and rear guide pins (5, Figure 19). Bent or broken pins indicate misuse; check for proper specimen engagement and proper jaw face sizing for the specimen being tested. If damage is not severe, a pin can be straightened. If straightening is not possible or if a pin is broken, the pin should be replaced.
  - Check for sharp edges or deformed corners that could inhibit motion of the jaw carriers or cause damage to wear plates. If damage is not severe, the edges and corners can be filed smooth. If damage can not be repaired, the jaw carriers should be replaced.
  - It is highly recommended that the wear plates are replaced anytime the jaw carriers are replaced (see step 5).
8. Clean and inspect grip pockets:
  - a. Clean all dirt, debris and lubricant from each grip pocket.
  - b. Inspect each grip pocket for damage. For frames with G1-style crossheads, use a flashlight to illuminate the surfaces of the grip pocket. Check for signs of wear, galling, scoring or other damage. Light scoring should be smoothed with a file or pneumatic sander. If deformation of the pocket or severe scoring is noticed, contact your local Instron Services department as directed on page 19. It may be possible to correct problems by machining.
9. **For frames with G1-style crossheads:** Reassemble components:
  - a. Install grip stop plate to top of tension crosshead and bumper plate to bottom of adjustable crosshead.
  - b. Reassemble and lubricate components according to the instructions outlined in “Install grip jaws - G1-style crossheads” on page 43.
10. **For frames with G7-style crossheads:** Reassemble components:
  - a. Install jaw carriers into grip pocket. Place the groove in the bottom of the jaw carrier over the edge of the push plate and slide jaw carrier into the grip pocket. Be sure that the guide pin in the rear of the jaw carrier enters the slot in the rear guide plate.
  - b. Install a wear plate between each jaw carrier and the side of the grip pocket.
  - c. Clean the threads of the guide plate cap screws (removed in step 4) with Loctite® ODC-FREE Cleaner and Degreaser 7070.
  - d. Apply a small amount of Loctite 246® Threadlocker High Temperature/Medium Strength to the threads of the cap screws.

- e. Install guide plates to front of each crosshead and secure in place with the prepared cap screws. Torque each cap screw to 200 N-m (150 ft-lbs).
- f. Lubricate the grip assemblies as outlined in “Lubricate the grip assemblies” on page 67.

11. The grip assemblies are now ready for normal operation.

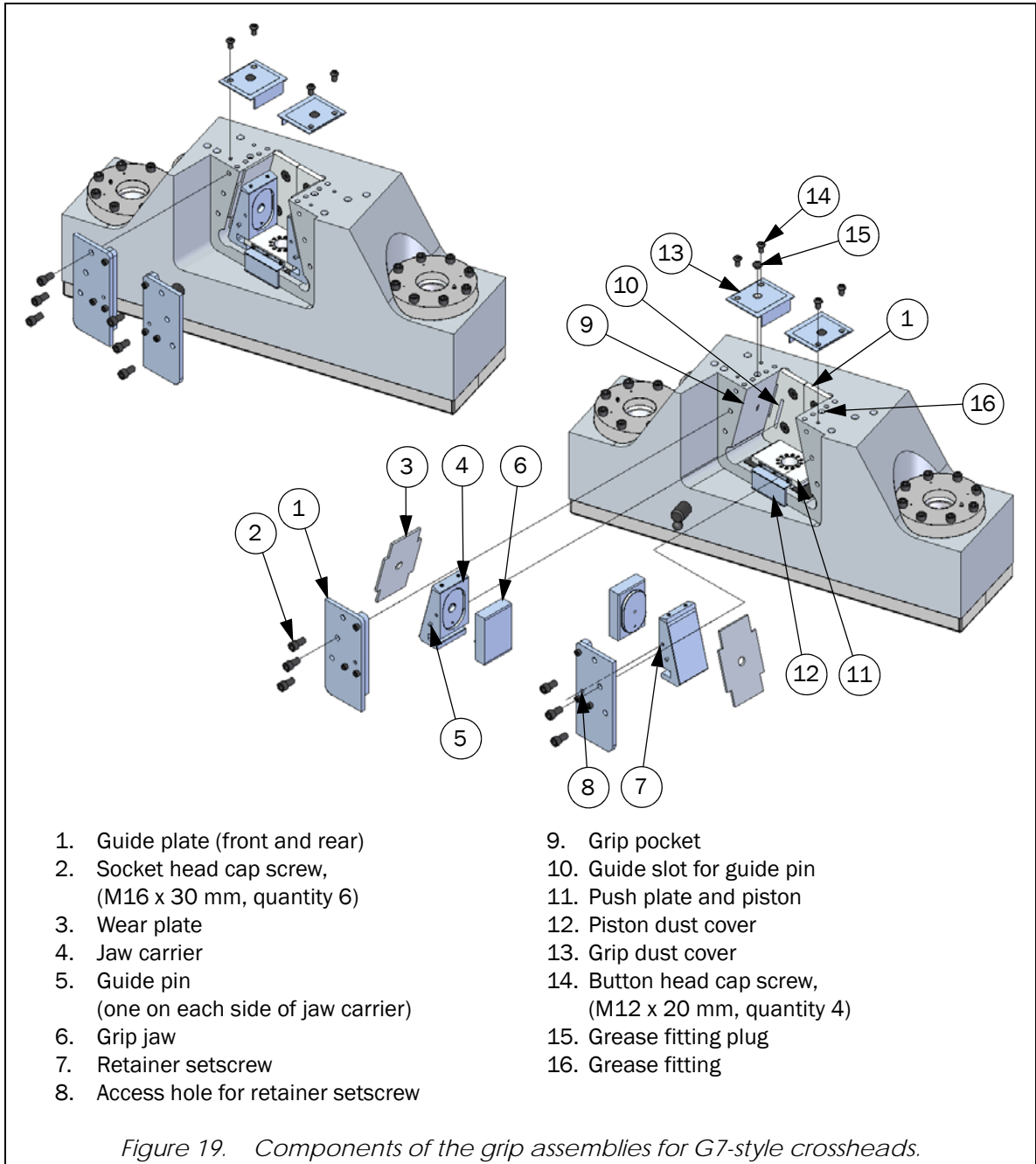

## Inspect and replace the pinion - G1-style crossheads

For frames with G1-style crossheads, a pinion should be replaced if it no longer operates the grip jaws correctly. For correct operation, the ends of the grip jaws should always be aligned with each other as they are opened or closed (see [Figure 20](#)). To check operation, install a set of grip jaws in the grip pocket and then operate the crank handle to open and close the grip jaws. Watch the grip jaws as they open and close, they should maintain correct alignment throughout the motion. If they do not, then perform the following check to determine why alignment is not being maintained:

1. Remove each grip jaw from the grip pocket and check its rack teeth. If rack teeth are broken, then this could be the cause for incorrect alignment or operation. Grip jaw may need to be replaced.
2. Visually inspect the pinion. Turn the crank handle and watch the pinion inside the grip pocket (if necessary use a flashlight to illuminate the pinion). Watch for broken teeth. Some amount of broken teeth are acceptable, but if it is affecting operation of the jaws, then the pinion will need to be replaced.
3. Check that the pinion is secure in the crosshead. The pinion should not move in or out of the crosshead, it should only rotate. If the pinion is able to move in and out of the crosshead, then the pinion is not centered properly in the crosshead. This must be corrected; perform [step 7](#) of the procedure to install a new pinion (on [page 76](#)).

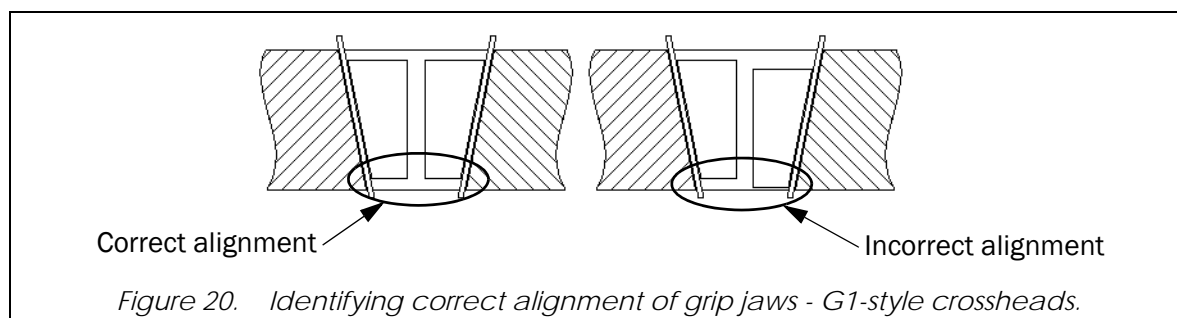

### Equipment required

- An 5 mm hex key (supplied)

### Recommended procedure

To install a new pinion, perform the following procedure. If it is only necessary to center the pinion, perform [step 7](#) of the following procedure.

1. Remove the crank handle from the pinion.
2. Loosen, but do not remove, the setscrew that holds the pinion in the crosshead (use hex key). The setscrew is accessed through a hole in the crosshead. The access hole is located on the top of each crosshead, toward the front and just above the crank handle.
3. Remove the pinion from the crosshead.
4. Insert the new pinion into the crosshead; be sure to insert the rounded end of the pinion first. The square end of the pinion (that accepts the crank handle) should be protruding from the crosshead, see [Figure 21](#). Also be sure that the flat area that accepts the setscrew is facing up.
5. Install the crank handle onto the end of the pinion. Be sure not to rotate the pinion while installing the crank handle, it is important that the flat area remains facing up.
6. Tighten the setscrew against the pinion just until seated.

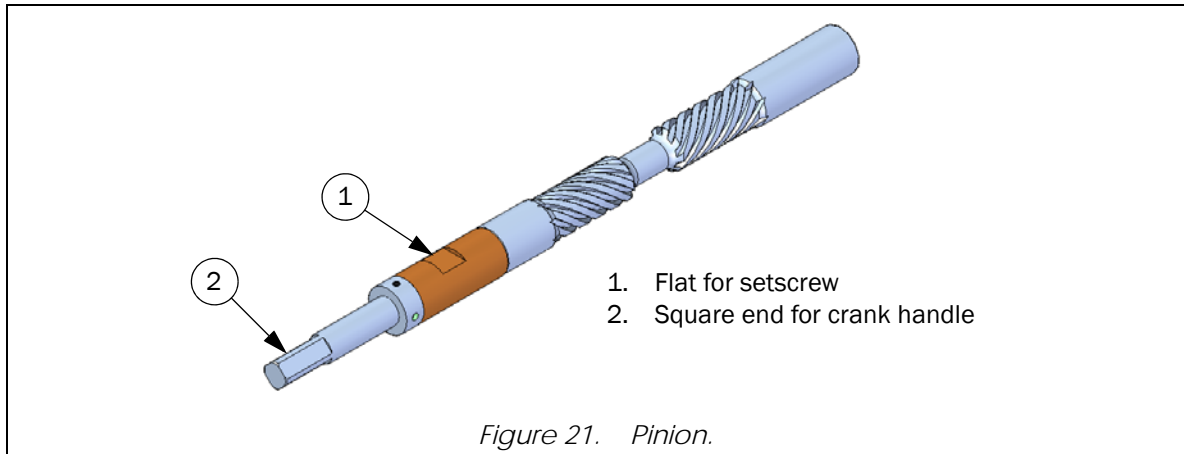

7. Center the pinion in the crosshead:
  - a. Install a set of grip jaws into the grip pocket. Do not install filler plates.
  - b. Rotate the crank handle and watch the motion of the grip jaws. Rotate the crank handle until the ends of the grip jaws lift out of the pocket opening and a clicking sound is heard.
  - c. Loosen the setscrew just enough to allow the pinion to move in and out of the crosshead. Pull the pinion in and out of the crosshead until the ends of the grip jaws are aligned with each other, see [Figure 20](#).
  - d. Tighten the setscrew against the pinion just until seated. Do not overtighten the setscrew. This could crimp the bronze bushing against the pinion and prohibit rotation of the pinion. Rotate the crank handle to check pinion rotation.

## Hydraulic power supply (HPS)

The HPS should be maintained according to the [“Preventative maintenance schedule”](#) on page 57.

### Check the oil cleanliness

The cleanliness of the oil in the reservoir should be checked at the frequency stated in the [“Preventative maintenance schedule”](#) on page 57. Check the appearance of the oil through the sight gauge; it should be a clear amber color. If the oil appears dirty, it should be changed (see [“Change the oil”](#) on page 79).



*In the United States and Canada, an oil sample test kit is available for purchase from Instron Services; contact your local Instron Services department as directed on page 19 for more information about the test kit.*

### Add oil to reservoir

It should only be necessary to add oil to the reservoir if an oil leak is evident or if the oil temperature/level switch indicates that the level of the oil is below the allowable level. However, the oil level should be checked at the frequency stated in the [“Preventative maintenance schedule”](#) on page 57. Check the oil level through the sight gauge on the HPS. The oil should be to the top of the sight gauge when the frame’s hydraulic cylinder is fully retracted. When it is necessary to add oil, perform the following procedure.

## Equipment and supplies required



All equipment and supplies must be supplied by the customer unless noted as “supplied”. For a list of equipment that was supplied with the system, refer to “[Ancillary parts](#)” on page 83.

- A 4 mm hex key (supplied)
- A clean funnel with a mesh filter
- Clean towels, rags, or similar
- Hydraulic fluid (amount required depends on how much is needed to sufficiently fill reservoir), for fluid specifications see “[Oil type and quantity](#)” on page 82

## Recommended procedure

Refer to [Figure 22](#) on page 78 for identification of components.

1. Remove the rear cover from the console. Refer to “[Remove and install console covers](#)” on page 60.
2. Clean the area around the fill hole and air breather filter (7 and 6) to remove all dust, dirt and grime.
3. If the oil temperature/level switch has tripped and it is determined that the trip was caused by a low oil level, perform steps [b](#) through [d](#) of this procedure only. Otherwise, skip this step and continue with step [4](#).
  - a. Remove the air breather filter from the reservoir fill hole - push down and turn counterclockwise.
  - b. Insert the clean funnel with a mesh filter into the fill hole and add enough of the recommended hydraulic fluid to the reservoir until the oil is visible at the bottom of the sight gauge. This will reset the temperature/level switch.
  - c. Remove the funnel.
  - d. Install the air breather filter onto the reservoir fill hole.
4. Start the HPS and fully retract the hydraulic cylinder.
5. Press the **DISABLE FRAME** button in the controlling software to shut down the HPS.
6. Remove the air breather filter from the reservoir fill hole - push down and turn counterclockwise.
7. Insert a clean funnel with a mesh filter into the fill hole and fill the reservoir with the recommended hydraulic fluid. Fill the reservoir to the top of the sight gauge.
8. Install the air breather filter onto the reservoir fill hole.
9. Start the HPS and cycle the hydraulic cylinder through its full stroke a few times. Fully retract the hydraulic cylinder. Press the **DISABLE FRAME** button in the controlling software to shut down the HPS. Check the oil level. If the oil is not to the top of the sight gauge, repeat steps [6](#) through [9](#). If the oil is to the top of the sight gauge, continue with next step.
10. Install the cover that was removed in step [1](#).

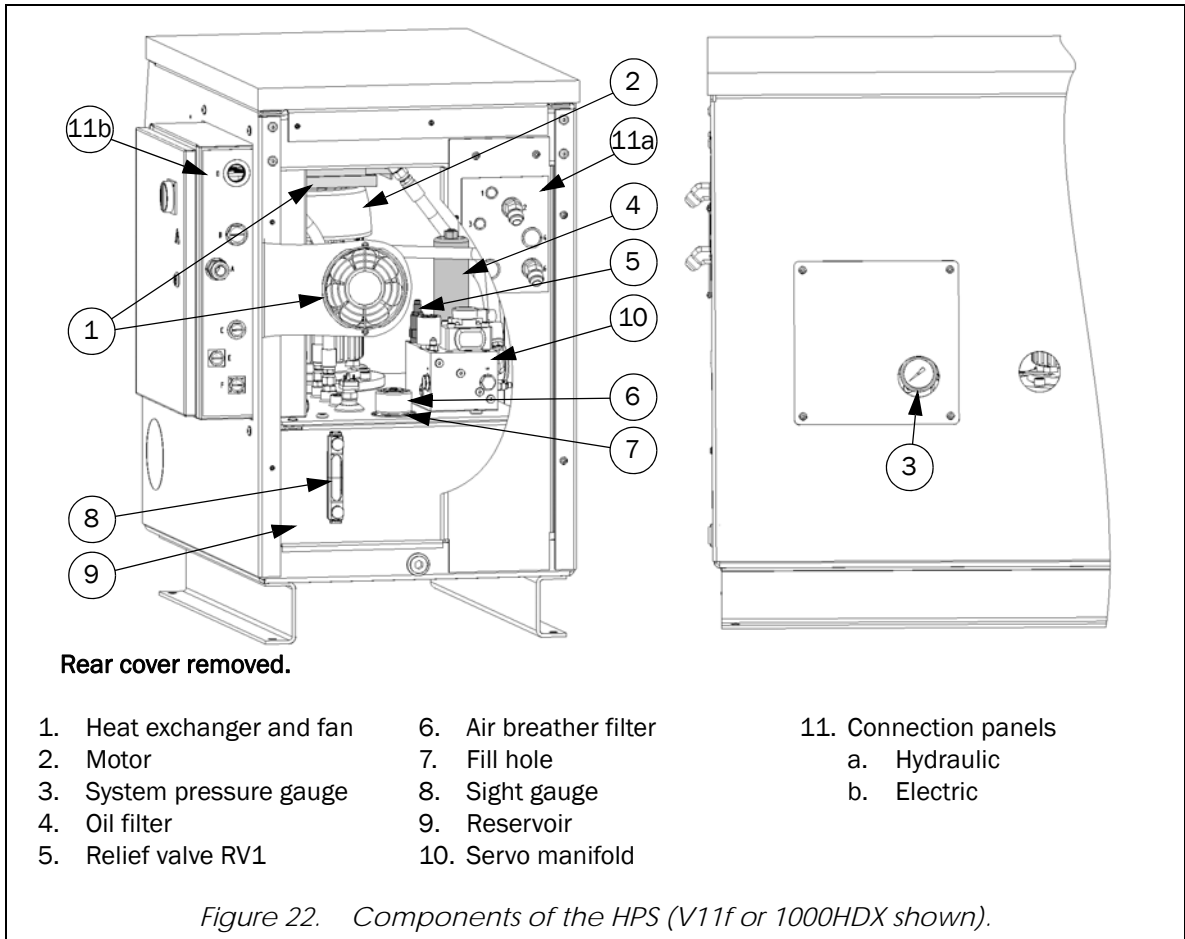

## Change the oil

The oil in the reservoir should be changed at the frequency stated in the “[Preventative maintenance schedule](#)” on page 57, or if the oil is determined to be dirty during a visual inspection (see “[Check the oil cleanliness](#)” on page 76). The oil filter should be changed every time that the oil is changed. The following procedure includes steps to change the oil filter.

### Equipment and supplies required

- A 3 mm hex key
- A 4 mm hex key
- A 9/16 in socket
- A 7/8 in socket
- A 1 in deep socket
- A ratchet wrench (for the sockets that are listed above - may also need a socket adapter depending on what the drive size requirements are)
- A torque wrench with range of at least 20 to 68 N-M (15 to 50 lbf-ft) (for the sockets that are listed above - may also need a socket adapter depending on what the drive size requirements are)
- A hand pump or similar to remove oil from reservoir
- A clean funnel with a mesh filter
- An oil container for collection of used oil
- Clean towels, rags, or similar
- Hydraulic fluid, for fluid specifications and amount required see “[Oil type and quantity](#)” on page 82
- New oil filter element - for Instron part number see [Table 17](#) on page 85
- New air breather filter - for Instron part number see [Table 17](#) on page 85

### Recommended procedure

Refer to [Figure 22](#) on page 78 for identification of components.

1. Remove the rear cover from the console. Refer to “[Remove and install console covers](#)” on page 60.
2. Start the HPS and fully retract the hydraulic cylinder.
3. Press the **DISABLE FRAME** button in the controlling software to shut down the HPS.
4. Change the oil filter:
  - a. Clean the outside surfaces of the filter and manifold (4 and 10) with a cleaning solvent to remove all dust, dirt and grime. Wipe dry with a clean towel.
  - b. Remove the vent plug from the top of the filter housing (use 9/16 in socket and ratchet wrench).
  - c. Locate relief valve “RV1” on the servo manifold (5). Loosen the relief valve (use 1 in deep socket and ratchet wrench). By hand, continue to loosen and slowly remove the relief valve. This allows oil to drain from the filter.
  - d. Wrap the relief valve in a clean towel to keep it clean, and set it aside.
  - e. Carefully loosen the filter housing (use 7/8 in socket and ratchet wrench). By hand, continue to loosen and slowly remove the filter housing.
  - f. Wrap the filter housing in a clean towel to keep it clean, and set it aside.

- g. Very gently remove the filter element. Oil from the inner part of the filter element will drain out and return to tank. Be careful not to shake any dirt off of the element and into the oil. Properly dispose of the filter element.
  - h. Inspect the filter cavity for damage. Wipe the filter cavity with a clean towel to remove all debris.
  - i. Install the new filter element. Carefully slide it over the bushing at the bottom of the filter cavity.
  - j. Inspect the filter housing and seals for damage. Wipe them with a clean towel to remove all debris.
  - k. Apply clean hydraulic oil to the threads of the filter housing (as a lubricant).
  - l. Install the filter housing over the filter element. Tighten the filter element by hand until you feel resistance from the seals. Change to the 7/8 in socket and ratchet wrench and continue to tighten the filter element until fully seated. Change to the torque wrench and tighten the filter housing to a torque of 61 N-m (45 lbf-ft).
  - m. Wipe the area around the port for the relief valve with a clean towel to remove all debris.
  - n. Carefully install the relief valve in the port. Tighten the valve by hand until it is seated in the port and you feel resistance from the seal. Continue to tighten the relief valve (use 1 in deep socket and torque wrench) to a torque of 34 N-m (25 lbf-ft).
  - o. Install the vent plug into the top of the filter housing (use 9/16 in socket and ratchet wrench) until snug and then back it out one full turn.
5. Purge air from the oil filter:
- a. Make sure the HPS is shut down.
  - b. Put towels around the base of the oil filter to absorb leaking oil.
  - c. Start the HPS and monitor the flow of oil from the vent plug. Watch for air bubbles in the oil. Run the HPS until there are no more air bubbles. Clean up any leaking oil.
  - d. Press the **DISABLE FRAME** button in the controlling software to shut down the HPS.
  - e. Tighten the vent plug (use 9/16 in socket and torque wrench) to a torque of 20 N-m (15 lbf-ft). Clean up any leaking oil.
  - f. Start the HPS and let it run for approximately ten minutes. While the HPS is running watch the oil filter and vent plug for oil leakage. If there is oil leakage, check and tighten the appropriate component.
  - g. When there is no oil leakage, cycle the hydraulic cylinder through its full stroke several times to ensure proper operation and to completely purge air from the system.
  - h. Press the **DISABLE FRAME** button in the controlling software to shut down the HPS.
6. Clean the HPS of all spilled and leaked oil. Clean the area around the fill hole and air breather filter (7 and 6) to remove all dust, dirt and grime.
7. Remove the air breather filter from the reservoir fill hole - push down and turn counterclockwise.
8. Remove the screws from the air breather fitting (use 3 mm hex key) on the reservoir. Remove the fitting and plastic screen from the reservoir fill hole.
9. Insert the hand pump hose into the reservoir.
10. Pump the oil out of the reservoir and into the oil container.
11. Install the air breather fitting and plastic screen into the reservoir fill hole. Secure the air breather fitting to the reservoir with the screws that were removed in step 8.
12. Insert a clean funnel with a mesh filter into the fill hole and fill the reservoir with the recommended hydraulic fluid. Fill the reservoir to the top of the sight gauge.



13. Install the air breather filter onto the reservoir fill hole.
14. Start the HPS and cycle the hydraulic cylinder through its full stroke a few times. Fully retract the hydraulic cylinder. Press the **DISABLE FRAME** button in the controlling software to shut down the HPS. Check the oil level. If the oil is not to the top of the sight gauge, repeat step 7 and then steps 12 through 14. If the oil is to the top of the sight gauge, continue with next step.
15. Install the cover that was removed in step 1.

## Change the air breather filter

The air breather filter should be changed at the frequency stated in the “[Preventative maintenance schedule](#)” on page 57.

## Equipment and supplies required

- New air breather filter - for Instron part number see [Table 17](#) on page 85



*When ordered from Instron, the air breather filter includes a new air breather fitting and plastic screen. The only part needed is the air breather filter. However, you can replace the existing air breather fitting and plastic screen with the new parts if desired or necessary (due to damage, etc.).*

## Recommended procedure

Refer to [Figure 22](#) on page 78 for identification of components.

1. Remove the rear cover from the console. Refer to “[Remove and install console covers](#)” on page 60.
2. Clean the area around the fill hole and air breather filter (7 and 6) to remove all dust, dirt and grime.
3. Remove the air breather filter from the reservoir fill hole - push down and turn counterclockwise. Properly dispose of the air breather filter.
4. Install the new air breather filter onto the reservoir fill hole.
5. Install the cover that was removed in step 1.

## Inspect the hydraulic hoses

Hydraulic hoses should be inspected at the frequency stated in the “[Preventative maintenance schedule](#)” on page 57. Check the following:

- Inspect all hose fittings for loose connections. This includes connections at the frame and at the HPS. Also be sure to check all hose fittings for any hydraulic accessories that are part of the testing system. Tighten any loose fittings that you may find.
- Inspect all hydraulic hoses for deterioration. Check for abrasions, cuts, etc. Replace hoses as necessary.

## Replace the hydraulic hoses

Hydraulic hoses should be replaced at the frequency stated in the “[Preventative maintenance schedule](#)” on page 57. The service life of any hydraulic hose depends on the pressure that it is subjected to during its normal use.

## Replace low pressure hydraulic hoses

Low pressure hoses are hoses that are normally subjected to pressures less than 20 bar (300 psi). Low pressure hoses would be:

- Drain hoses
- Return hoses between system components and the reservoir

## Replace high pressure hydraulic hoses

High pressure hoses are hoses that are normally subjected to pressures 20 bar (300 psi) and greater. High pressure hoses would be:

- Supply hose between the HPS and hydraulic cylinder
- For frames with G7-style crossheads, any supply hose between the HPS and hydraulic grip actuators

## Oil type and quantity

The International Standards Organization (ISO) viscosity designation for oil appropriate to use in the reservoir is ISO VG 32. An ISO VG 32 grade oil was used to fill the hydraulic reservoir before the equipment left the factory. As it becomes necessary to add to or replace the oil in the reservoir, use an ISO VG 32 grade oil. Many brand names contain this number. In general look for oils with the following properties: good demulsibility; low air entrainment; low pour point; and additives that protect against rust, corrosion, accelerated pump wear, foaming, and oxidation.

Approximate reservoir capacities for the various models of HDX frames can be found in [Table 15](#).

*Table 15. Approximate capacity of HPS reservoir.*

HPS Catalog Number and Model	Reservoir Capacity
1000HDX-D22, V11f	75 L (20 gal)
1500HDX-D14, V12f	170 L (45 gal)

## Clean the air filter

The HPS is equipped with an air filter to clean the air as it enters the HPS. The filter is located on the right side of the console in front of the electrical box. The filter should be maintained at the frequency stated in the [“Preventative maintenance schedule”](#) on page 57. Remove the filter from the filter guard through the opening in the top of the guard. Clean the filter with water or vacuum as necessary. Return the filter to the filter guard.

## Ancillary parts

HDX systems are provided with operating tools and other accessories that are either: required to complete installation of the frame; required for use or maintenance of frame; or required for set up of accessories on the frame. These ancillary parts are included with the frame upon delivery. Ancillary parts for the various HDX systems are listed in [Table 16](#). Be sure to keep these ancillary parts in a safe place so they do not get misplaced.

Table 16. Ancillary parts list.

Description	Location or Purpose	Frame Model	Part Number <sup>1</sup>	Quantity
Filler plate, 1/8 in thick	Grip assemblies	1000HDX-G1	141479-4B	4
		1500HDX-G1	147960-2C	4
Filler plate, 1/4 in thick	Grip assemblies	1000HDX-G1	141479-4C	4
		1500HDX-G1	147960-2B	4
Filler plate, 1/2 in thick	Grip assemblies	1000HDX-G1	141479-4D	4
		1500HDX-G1	147960-2A	4
Pinion	Grip assemblies	1000HDX-G1	222736-2	2
		1500HDX-G1	226255-2	2
Setscrew, M10 x 1.5p x 40 mm	Grip assemblies - secure pinion	1000HDX-G1	300-8822-9521	2
Setscrew, M10 x 1.5p x 25 mm	Grip assemblies - secure pinion	1500HDX-G1	300-8822-9464	2
Crank handle	Grip assemblies	1000HDX-G1	300-8876-1006	2
		1500HDX-G1	300-8876-1008	2
Grip stop	Grip assemblies - tension crosshead	1000HDX-G1	222739-1	1
		1500HDX-G1	227622-1	1
Socket head cap screw, M16 x 2p x 45 mm	Grip assemblies - secure grip stop	1000HDX-G1	300-8821-9505	2
Socket head cap screw, M20 x 2.5p x 90 mm	Grip assemblies - secure grip stop	1500HDX-G1	300-8821-9544	2
Jaw retainer	Grip assemblies - tension crosshead	1000HDX-G1	222738-2	4
		1500HDX-G1	227621-1	2
Button head cap screw, 3/8-16 x 3/4 in	Grip assemblies - secure jaw retainer	1000HDX-G1	300-8826-1027	8
Button head cap screw, 1/2-13 x 3/4 in	Grip assemblies - secure jaw retainer	1500HDX-G1	300-8821-1367	4
Wear plate	Grip assemblies - top of tension crosshead	1500HDX-G1	226259-1	2
	Grip assemblies - top of adjustable crosshead	1500HDX-G1	226252-1	2
Flat head cap screw, M10 x 1.5p x 25 mm	Grip assemblies - secure wear plates to top of crosshead	1500HDX-G1	300-8824-9193	8

Table 16. Ancillary parts list. (Continued)

Description	Location or Purpose	Frame Model	Part Number <sup>1</sup>	Quantity
Bumper plate	Compression test space	1000HDX-G1	228272-2	1
		1500HDX-G1	226189-3	1
Setscrew, M8 x 1.25p x 25 mm	Compression test space - secure holding button to bumper plate	1000HDX-G1 1500HDX-G1	300-8822-9550	1
Socket head cap screw, M12 x 1.75p x 50 mm	Compression test space - secure bumper plate to adapter	1000HDX-G1	300-8821-9234	2
Socket head cap screw, M20 x 2.5p x 80 mm	Compression test space - secure bumper plate to crosshead	1500HDX-G1	300-8821-9487	2
Lubricant, Molykote GN metal paste, 1 lbs can	Grip assemblies	1000HDX-G1 1500HDX-G1	300-8894-9035	1
Socket, 14 mm, hex bit 1/2 in square-drive (requires customer supplied wrench with 1/2 in square-drive)	Tighten and loosen M16 SHCS for guide plates	1000HDX-G7 1500HDX-G7	300-8875-9377	1
Screwdriver, 3/8 in slot, 8 in long	Assist in removal of magnetic grip jaws from grip pocket	1000HDX-G7 1500HDX-G7	300-8899-10699	1
Hex key, T-handle, 4 mm, 6 in blade	Tighten and loosen M5 cap screws	1000HDX-G7 1500HDX-G7	300-8875-9369	1
Wear plate	Extra set for grip assemblies	1000HDX-G7 1500HDX-G7	225906-1	4
Piston dust cover	Grip assemblies	1000HDX-G7 1500HDX-G7	222717-1	2
Lubricant, Molykote GN metal paste, 14 oz cartridge	Grip assemblies	1000HDX-G7 1500HDX-G7	300-8894-9059	2
Grease gun	Grip assemblies	1000HDX-G7 1500HDX-G7	300-8899-10682	1
Adhesive, Loctite 246 Threadlocker high temperature/ medium strength, 10 mL (0.34 oz)	Grip assemblies	1000HDX-G7 1500HDX-G7	300-8899-10741	1
Cleaner and degreaser, Loctite 7070 ODC-FREE, 475 mL (16 oz) spray	Grip assemblies	1000HDX-G7 1500HDX-G7	300-8899-10742	1
Hex key set, 13 piece, 0.050 - 3/8 in ball end	Tighten and loosen various fasteners	All	300-8875-1958	1
Hex key set, 9 piece, 1.5 - 10 mm ball end	Tighten and loosen various fasteners	All	300-8875-9290	1

1. Part numbers are listed for reference only. Some parts can not be ordered using these numbers; contact your local Instron Services department as directed on page 19 to order parts.

## Consumable parts

HDX systems are designed to require very few parts to be replaced during their lifetime. These consumable parts are listed in [Table 17](#). The replacement frequency of each part, or the condition that indicates that replacement is necessary, is discussed throughout this chapter.

Table 17. Consumable parts list.

Description	Location or Purpose	Frame Model	Part Number <sup>1</sup>
Lubricant, Molykote GN metal paste, 0.45 kgs (1 lbs) can	Lubricate grip assemblies	1000HDX-G1 1500HDX-G1	300-8894-9035
Lubricant, Molykote GN metal paste, 0.4 kgs (14 oz) cartridge	Lubricate grip assemblies	1000HDX-G7 1500HDX-G7	300-8894-9059
Adhesive, Loctite 246 Threadlocker high temperature/medium strength, 10 mL (0.34 oz)	Maintain grip assemblies	1000HDX-G7 1500HDX-G7	300-8899-10741
Cleaner and degreaser, Loctite 7070 ODC-FREE, 475 mL (16 oz) spray	Maintain grip assemblies	1000HDX-G7 1500HDX-G7	300-8899-10742
Lubricant, Molykote BR2 Plus, 0.4 kgs (14 oz) cartridge	Lubricate backlash eliminators	All	105-1-60
Lubricant, Molykote BR2 Plus, 16 kgs (35 lbs) can	Lubricate screw columns	All	300-8894-9064
Oil filter element (3 micron)	HPS - oil filter	All	300-8873-9150
Air breather filter	HPS - reservoir	All	300-8868-9091

1. Part numbers are listed for reference only. Some parts can not be ordered using these numbers; contact your local Instron Services department as directed on page [19](#) to order parts.

## Spare and replacement parts

The Instron Services department can supply parts for your system. In the event that your system requires replacement parts, or if you choose to keep spare parts in stock, please contact your local Instron Services department as directed on page [19](#) for the proper part.



# Appendix A

## Grip Jaws

A range of grip jaws are available for use with the frame's grip assemblies. [Table 18](#) lists the catalog numbers and specifications of grip jaws that are available. In addition, other grip jaws can be ordered and made to customer specifications; contact your regional Instron office or check our web site at [www.instron.com](http://www.instron.com) for assistance.

### Caution

Always use grip jaws that are designed for the size of the specimen that you are testing. Using undersized specimens for your grip jaws can cause damage to the grips.

Table 18. Available grip jaws and their specifications.

Frame Model	Grip Jaw Catalog Number	Jaw Type <sup>1</sup>	Specimen Range <sup>2</sup>	Tooth Profile	Jaw Face Size (W x H)	Minimum Engagement
1000HDX-G1	W-1559	Flat-face	0-50 mm (0-2 in)	8 tpi, diamond, 65 deg.	82 x 150 mm (3.25 x 6 in)	120 mm (4.8 in)
	W-1560			16 tpi, diamond, 65 deg.		
	W-1561	Vee-face	12.7-57 mm (0.5-2.25 in)	10 tpi, horizontal, 65 deg.		
	W-1562		45-85 mm (1.75-3.25 in)	16 tpi, horizontal, 65 deg.		
	W-1563-A		6-12.7 mm (0.25-0.5 in)	16 tpi, horizontal, 65 deg.		
	W-1563		12.7-57 mm (0.5-2.25 in)	16 tpi, horizontal, 65 deg.		
1500HDX-G1	W-1660	Flat-face	0-76 mm (0-3 in)	8 tpi, diamond, 65 deg.	90 x 170 mm (3.5 x 6.75 in)	135 mm (5.4 in)
	W-1662	Vee-face	12.7-82 mm (0.5-2.25 in)	10 tpi, horizontal, 65 deg.		
	W-1669-A		10-63 mm (0.375-2.5 in)	8 tpi, horizontal, 65 deg.		
1000HDX-G7 1500HDX-G7	W-5331-A	Flat-face	0-35 mm (0-1.38 in)	8 tpi, horizontal, 65 deg.	100 x 150 mm (4 x 6 in)	120 mm (4.8 in)
	W-5331-B		35-70 mm (1.38-2.76 in)			
	W-5332-C	Vee-face	3-12 mm (0.12-0.47 in)	20 tpi, horizontal, 65 deg.		
	W-5332-A		12-45 mm (0.47-1.77 in)	10 tpi, horizontal, 65 deg.		
	W-5332-B		45-70 mm (1.77-2.75 in)	10 tpi, horizontal, 65 deg.		

## Appendix : Grip Jaws

---

1. Flat-face grip jaws are for testing square or rectangular specimens.  
Vee-face grip jaws are for testing round specimens.
2. For flat-face grip jaws this is the specimen thickness.  
For vee-face grip jaws this is the specimen diameter.





The background of the page is an abstract composition of soft, flowing curves in shades of light gray and white. A prominent feature is a pattern of small, light gray dots arranged in a grid, which is partially obscured by the larger, smoother curves. The overall aesthetic is clean, modern, and technical.

Product Support: [www.instron.com](http://www.instron.com)